

ADEMCO**998PI/998EXPI**
PASSIVE INFRARED MOTION DETECTORS**INSTALLATION INSTRUCTIONS****GENERAL INFORMATION**

These passive infrared motion detectors are versatile wall-mounted units employing Fresnel lenses and offering efficient protection patterns for commercial and residential applications. Best coverage will be obtained if mounting is selected such that the likely direction of intruder motion is across the pattern.

When installed per the guidelines, the Split-Zone Optics technology in the 998PI and 998EXPI (with tamper switch) provide reasonable false alarm protection against pets and other animals up to 40 lbs.

SPECIFICATIONS

Detection Method:	Passive Infrared.
Coverage:	Pet Immune Lens, 35 ft x 45 ft (10.6m x 13.7m), 90°.
Detection Zones:	Pet Immune Lens - 30 zones (8 long range, 7 over 7 intermediate, 4 over 4 short range).
Pulse Count:	Intermediate or Standard selectable via DIP switch. Note: Use Standard for pet immune applications.
Detectable Walk Rate:	0.5 - 10ft/sec (0.15 - 3m/sec).
Mount Height:	7.5 ft recommended (2.3m).
Indicator:	Red LED; enabled/disabled via DIP switch.
Alarm Relay:	Form A, SPST, 90mA@16V DC 15-ohm protective resistor.
Input Voltage:	10 - 16VDC (voltage reversal makes PIR inoperative).
Current:	18mA (non-alarm), nominal. 16mA (alarm), nominal.
Standby:	Power source should be capable of at least 4 hours of battery standby.
Tamper:	Normally closed (with cover on), rated at .5A, 30VDC (998EXPI only).
Operating Temp.:	14°F - 122°F (-10°C to +50°C).
Operating Humidity:	Up to 95% RH (max.), non-condensing.
Dimensions:	2-5/8"W x 4-3/8"H x 2-1/8"D (max protrusion) (67mm x 111mm x 54mm).

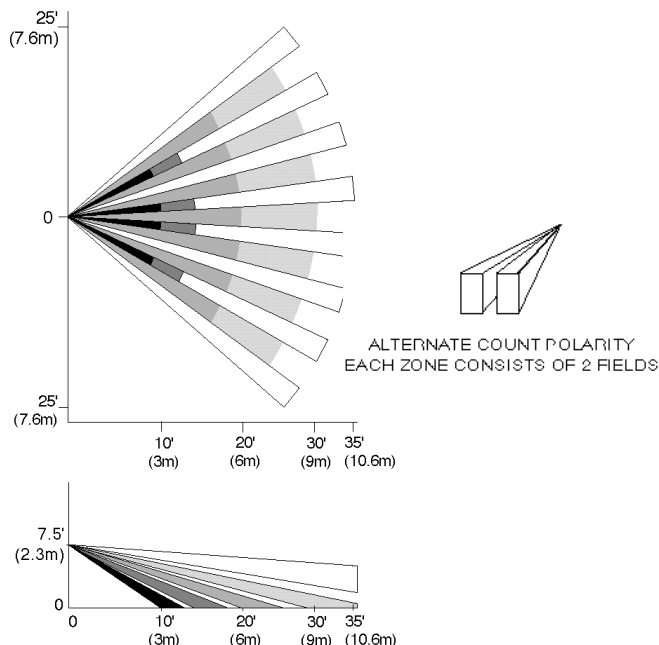

Figure 1. Protection Pattern

Special Instructions
for Installations Containing Pets

To take full advantage of the pet immunity in the 998PI or 998EXPI, the following guidelines should be followed:

- Mount the center of the detector 6-1/2 to 7-1/2 feet (2.0m - 2.3m) high and adjust the vertical angle according to Table 1.
- Set the PIR sensitivity for Standard (STD).
- Mount where animals cannot come within six feet of the detector by climbing on furniture, boxes, or other objects.
- Do not aim the detector at stairways that can be climbed by animals.
Note: This unit will provide immunity to false alarms for an individual animal or a group of animals whose total weight is equal to or less than 40 pounds when the room temperature is above 50°F (10°C).

INSTALLATION

For optimal pet immunity performance, be sure to follow all the guidelines described in the section "Special Instructions for Installations Containing Pets."

A. Normal Surface Mounting

Mount the unit to a firm vertical surface. The wall wiring hole should be no more than 5/16" (8mm) in diameter.

1. Remove the front cover as shown in Figure 1.
2. Refer to Figure 2. Knockout holes "A" in the base are for normal surface mounting on a wall (slide PC board up for access to bottom holes, down for access to top holes). For corner mounting, see **B. Corner Mounting**. Also break out the desired wire entry hole at this time, marked X1 or X2 in Figure 2).
3. Feed wiring emerging from the wall through the wire access hole **near the top** of the detector base. Make sure wires have sufficient slack to allow the PC board to be moved up and down freely when the wires are connected to the terminals on the board.
4. Mount the base. **Note the mounting orientation of this detector - wire entry at the top, lens at the bottom!** Make sure the board is positioned so that the arrow is in line with the appropriate setting on the graduated scale (see Figure 5 and Table 1).
5. Refer to the **WIRING CONNECTIONS** section before replacing the front cover.

B. Corner Mounting

Knockout holes "B" in the base are used for corner mounting on a wall (slide PC board up for access to bottom holes, down for access to top holes). Mount in selected corner with 4 screws.

Note the mounting orientation of this detector - wire entry at the top, lens at the bottom! Make sure the board is positioned so that the arrow is in line with the appropriate setting on the graduated scale (see Figure 5 and Table 1).

C. Changing Lenses (if required)

1. Remove front cover.
2. Release the lens support frame located in front cover as follows: Insert the blade of a small screwdriver between the locking tab and the detector case in each of the four corners of the frame, and lever each tab upward to release. See Figure 4. When all four corners are released, remove the lens support frame.
3. Remove the existing lens and replace with the replacement lens. **The lens must be installed with the smooth side facing outward. Also, the lens should be oriented with its part number on the upper right-hand side (see Figure 4).** Be sure to center the lens.
Note: Lens surface should be free of dirt, foreign matter and fingerprints. Use a clean dry soft cloth to wipe lens surfaces.
4. Insert the lens support frame into its original position and then press downward on the frame so that the lens locking tabs snap into position in each of the four corners.

5. Refer to **E. Vertical Pattern Adjustment** and Table 1 for recommended detector pattern setting for various mounting heights and protection ranges.
6. Replace front cover.

D. Horizontal Adjustment of Lens

The protection pattern can be moved to the left or right by horizontal adjustment as follows:

1. Remove front cover.
2. Release the lens frame as shown in Figure 4.
3. Grasp the lens firmly on both sides (front and back) and slide the lens to the left or right, as needed. The lens may be moved as much as 4° (from center) in either direction.
4. Replace lens, lens frame and the front cover.

After adjustment, conduct a Walk-Test to ensure proper coverage of the area to be protected (see *TEST PROCEDURES*).

E. Vertical Pattern Adjustment

The protection pattern can be raised or lowered by repositioning the PC board in the detector. A graduated scale to the left of the board (see Figure 5) indicates the approximate number of degrees by which the pattern can be raised (max. +5°) or lowered (max. -20°). To make this adjustment, slide the board upward or downward by the number of degrees required. After any adjustment, conduct a Walk-Test to ensure proper coverage of the area to be protected (see *TEST PROCEDURES*).

Table 1 indicates the recommended setting at various mounting heights.

F. Lens Masking

The supplied masking strips can be used to produce a protection pattern that suits the particular requirements of the protected area, or eliminate coverage from areas where you anticipate environmental disturbances that might reduce the PIR's stability (a heater or other heat-producing object, for example). Simply peel off the appropriate pressure-sensitive adhesive strip(s) and apply over the desired lens segment(s). Be sure to affix the masking strips to the *inside* of the lens (not the outer, smooth side). Each lens segment that is masked results in the elimination of one zone of protection from the coverage pattern.

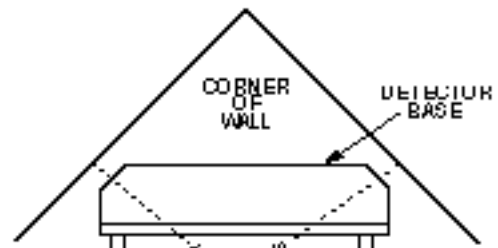

Figure 3. Corner Mounting

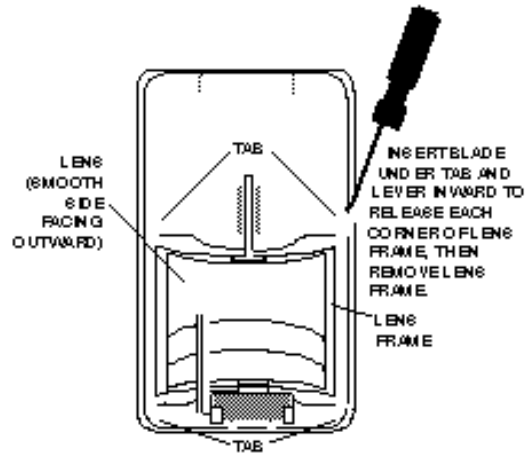

Figure 4. Changing Lenses

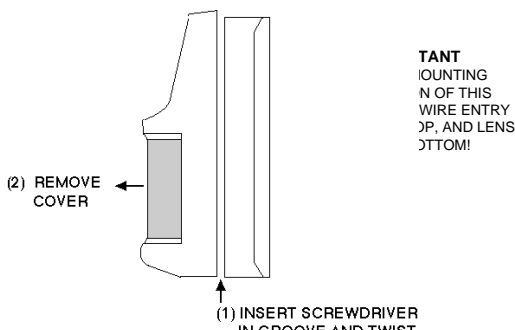

Figure 1. Cover Removal

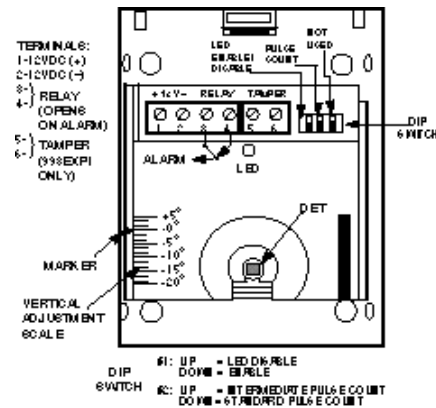

Figure 5. Wiring Connections

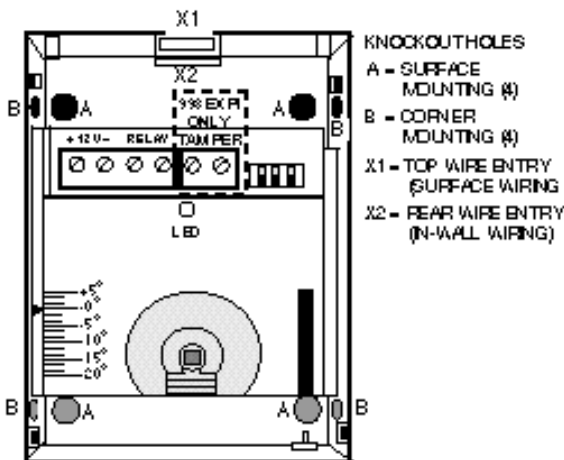

Figure 2. Detector Base

WIRING CONNECTIONS

Bring all wires in through the wire access slot at the top of the detector base (near the terminal block) and connect to the screw terminals (see Figure 5 for wiring details). Seal any openings in the base with foam or RTV (not supplied) to prevent drafts or insects from entering the unit. *Apply power only after all connections have been made and are inspected.*

LED ENABLE/DISABLE OPTION

To enable the LED, set the DIP switch #1 **DOWN** (see Figure 5 for switch location). To disable the LED, set DIP switch #1 **UP**. Use a small pointed tool to move the switch handle up or down.

PULSE COUNT OPTION

For Intermediate Pulse Count, set the Pulse Count DIP switch #2 **UP** (see Figure 5 for switch location). For Standard Pulse Count, set DIP switch #2 **DOWN**. Use a small pointed tool to move the

switch handle up or down.

Standard Pulse Count: This is the recommended setting for maximum false alarm immunity. It tolerates environment extremes on this setting.

Note: Standard Pulse Count is recommended for pet immune applications.

Intermediate Pulse Count: This is the recommended setting for any location where an intruder is expected to cover only a small portion of the protected area. It tolerates normal environments on this setting.

Note: NOT recommended for pet immune applications.

TEST PROCEDURES

Important: Two-minute warm-up time is required after applying power. Testing should be conducted with the protected area cleared of all people. Disarm the protective system's control during the test procedure to prevent reporting of unwanted alarms.

1. Remove front cover and set DIP switch #2 (Pulse Count) to the setting which will be used for this detector in the installation. The LED must be enabled at this time (DIP switch #1 down).
2. Replace front cover and walk through protective zones, observing that the detector's LED lights whenever motion is detected (the LED serves as a Walk-Test indicator during this procedure).

The absolute range of all PIR units is subject to variation because of different types of clothing, backgrounds and ambient temperature. For this reason, ensure that the most likely intruder routes are well within the PIR's protective zones and that Walk-Testing is carried out along these routes.

After the Walk-Test is complete, the LED may be disabled (DIP switch #1 UP).

MAINTAINING PROPER OPERATION

In order to maintain the detector in proper working condition, it is important that the user observe the following.

1. Power should be provided at all times. Loss of power to the unit will result in the alarm contacts reverting to an alarm state. The unit's DC source should have standby power available for at least 4 hours of operation during emergencies.
2. Units should never be re-aimed or relocated without the advice or assistance of the alarm service company.
3. The physical surroundings of the protected area should not be changed. If furniture or stock is moved, or air conditioning or additional heating is installed, the system may have to be readjusted by the alarm service company.
4. Walk-Tests should be conducted frequently (at least weekly) to confirm continued proper coverage by each detector.

TROUBLESHOOTING

INTERMITTENT ALARM (LED OPERATIVE)

- A. Rapid temperature change. Check for electric or gas heaters, open flames, electric arcs, etc.
Remedy: Locate source and reposition detector.
- B. Drafts causing drapes, light fixtures, display material to move.
Remedy: Eliminate source of motion.

INTERMITTENT OR CONTINUOUS ALARM

- A. DC voltage supplied to detector is inadequate or intermittent, or polarity is reversed.
Remedy: Ensure that polarity is corrected, adequate voltage is supplied, wiring is intact (no opens/shorts), and connections secure.
- B. Protective loop is interrupted (open).
Remedy: Determine whether interruption is in protective loop wiring or at detector's alarm relay contacts. Disconnect protective loop at detector relay contact terminals. Check continuity across terminals. If absent (and proper voltage is supplied to the detector), return unit for replacement. If present, check protective loop wiring.

LED INOPERATIVE

- A. LED DIP switch #1 in UP position.
Remedy: Set DIP switch #1 in DOWN position.
- B. LED malfunction.
Remedy: Check for broken/shorted leads. Return unit for replacement.

DETECTION AREA CHANGES

- A. Repositioned furniture or equipment in the protected area.
Remedy: Caution customer about layout changes. Reposition detector.
- B. Mounting surface is unstable. A few degrees of vertical shift can change range substantially.
Remedy: Mount on secure surface.

PANEL INDICATES CONTINUOUS FAULT IN ZONE OF PROTECTION CONTAINING PIRs (PIR's alarm LED not lit)

Too many detectors being used in the zone. Each detector adds 15 ohms of series resistance and the zone's allowable loop resistance is being exceeded.

Remedy: Reduce the number of detectors used in the zone until the series resistance is within the allowable loop resistance permitted by the control.

Table 1. PCB ADJUSTMENT FOR PET IMMUNE LENS

Use this position for 6.5ft - 7ft (2.0m - 2.1m) mounting height.

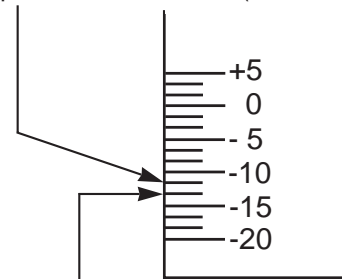

Use this position for 7-7.5ft (2.3m) mounting height.

———— Vertical Pattern Setting ————

Note: When setting angle, eyesight should be directly in front of scale to avoid parallax errors.

TO THE INSTALLER

Regular maintenance and inspection (at least annually) by the installer and frequent testing by the user are vital to continuous satisfactory operation of any alarm system.

The installer should assume the responsibility of developing and offering a regular maintenance program to the user, as well as acquainting the user with the proper operation and limitations of the alarm system and its component parts. Recommendations must be included for a specific program of frequent testing (at least weekly) to ensure the system's operation at all times.

THE LIMITATIONS OF THIS PASSIVE INFRARED MOTION DETECTOR

While the Intrusion Detector is a highly reliable intrusion detection device, it does not offer guaranteed protection against burglary. Any Intrusion Detection device is subject to compromise or failure to warn for a variety of reasons:

- Passive Infrared Motion Detectors can detect intrusion only within the designed ranges as diagrammed in this installation manual.
- Passive Infrared Motion Detectors do not provide volumetric area protection. They do create multiple beams of protection, and intrusion can be detected only in unobstructed areas covered by those beams.
- Passive Infrared Detectors cannot detect motion or intrusion that takes place behind walls, ceilings, floors, closed doors, glass partitions, glass doors, or windows.
- Mechanical tampering, masking, painting or spraying of any material on the lenses, windows or any part of the optical system can reduce the detection ability of the Passive Infrared Motion Detector.
- Passive Infrared Detectors sense changes in temperature; however, as the ambient temperature of the protected area approaches the temperature range of 90° to 105°F (32° to 40°C), the detection performance can decrease.
- This Passive Infrared Detector will not operate without appropriate DC power connected to it, or if the DC power is improperly connected (i.e., reversed polarity connections).
- Passive Infrared Detectors, like other electrical devices, are subject to component failure. Even though this equipment is designed to last as long as 10 years, the electronic components in it could fail at any time.

We have cited some of the most common reasons that a Passive Infrared Motion Detector can fail to catch intrusion. However, this does not imply that these are the only reasons, and therefore it is recommended that weekly testing of this type of unit, in conjunction with weekly testing of the entire alarm system, be performed to ensure that the detectors are working properly.

Installing an alarm system may make the owner eligible for a lower insurance rate, but an alarm system is not a substitute for insurance. Homeowners, property owners and renters should continue to act prudently in protecting themselves and continue to insure their lives and property.

We continue to develop new and improved protection devices. Users of alarm systems owe it to themselves and their loved ones to learn about these developments.

ADEMCO LIMITED WARRANTY

Alarm Device Manufacturing Company, a Division of Pittway Corporation, and its divisions, subsidiaries and affiliates ("Seller"), 165 Eileen Way, Syosset, New York 11791, warrants this detector to be in conformance with its own plans and specifications and to be free from defects in materials and workmanship under normal use and service for 72 months from the date stamp control on the product. Seller's obligation shall be limited to replacing, at its option, free of charge for materials or labor, a detector which is proved not in compliance with Seller's specifications or proves defective in materials or workmanship under normal use and service. Seller shall have no obligation under this Limited Warranty or otherwise if the detector is altered or improperly repaired or serviced by anyone other than Ademco factory service. In case of defect, return the detector to ADI or an authorized distributor for an immediate replacement.

THERE ARE NO WARRANTIES, EXPRESS OR IMPLIED, OF MERCHANTABILITY, OR FITNESS FOR A PARTICULAR PURPOSE OR OTHERWISE, WHICH EXTEND BEYOND THE DESCRIPTION ON THE FACE HEREOF. IN NO CASE SHALL SELLER BE LIABLE TO ANYONE FOR ANY CONSEQUENTIAL OR INCIDENTAL DAMAGES FOR BREACH OF THIS OR ANY OTHER WARRANTY, EXPRESS OR IMPLIED, OR UPON ANY OTHER BASIS OF LIABILITY WHATSOEVER, EVEN IF THE LOSS OR DAMAGE IS CAUSED BY THE SELLER'S OWN NEGLIGENCE OR FAULT.

Seller does not represent that its detector may not be compromised or circumvented; that the detector will prevent any personal injury or property loss by burglary, robbery, fire or otherwise; or that the detector will in all cases provide adequate warning or protection. Buyer understands that a properly installed and maintained alarm may only reduce the risk of a burglary, robbery, fire or other events occurring without providing an alarm, but it is not insurance or a guarantee that such will not occur or that there will be no personal injury or property loss as a result. CONSEQUENTLY, SELLER SHALL HAVE NO LIABILITY FOR ANY PERSONAL INJURY, PROPERTY DAMAGE OR OTHER LOSS BASED ON A CLAIM THE DETECTOR FAILED TO GIVE WARNING. HOWEVER, IF SELLER IS HELD LIABLE, WHETHER DIRECTLY OR INDIRECTLY, FOR ANY LOSS OR DAMAGE ARISING UNDER THIS LIMITED WARRANTY OR OTHERWISE, REGARDLESS OF CAUSE OR ORIGIN, SELLER'S MAXIMUM LIABILITY SHALL NOT IN ANY CASE EXCEED THE PURCHASE PRICE OF THE DETECTOR, WHICH SHALL BE THE COMPLETE AND EXCLUSIVE REMEDY AGAINST SELLER. This warranty replaces any previous warranties and is the only warranty made by Seller on this detector. No increase or alteration, written or verbal, of the obligations of this Limited Warranty is authorized.

ADEMCO GROUP

165 Eileen Way Syosset, New York 11791
Copyright © 1998 PITTWAY CORPORATION



N8023-7V1 8/98