

## **INSTALLATION INSTRUCTIONS**

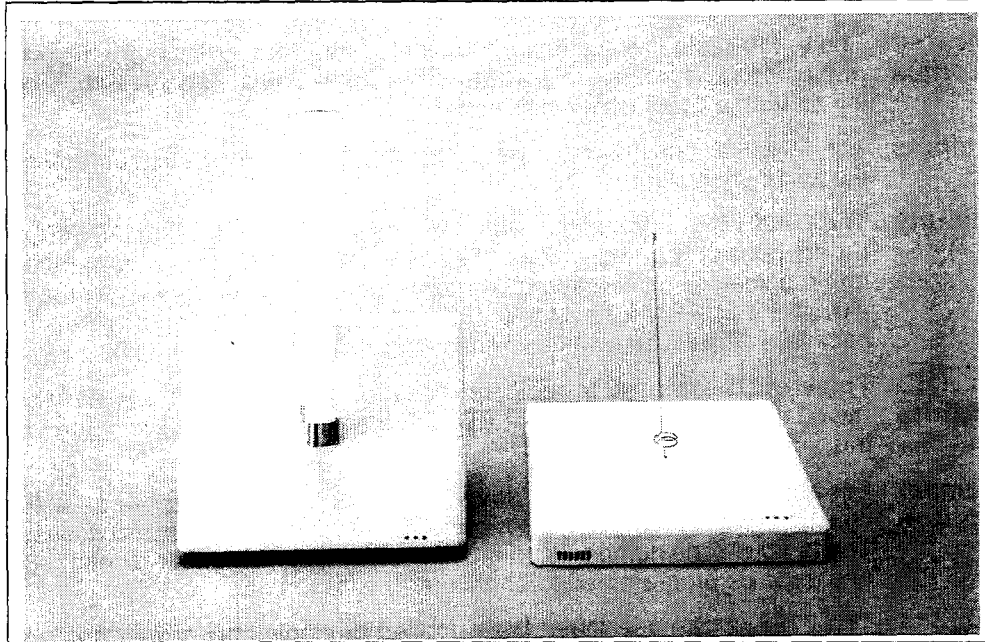

### **TABLE OF CONTENTS**

<b>SYSTEM FEATURES &amp; OPERATION.....</b>	<b>2</b>
Introduction.....	2
System Features .....	2
General Operation .....	3
LED Indications .....	3
Radio Fault Led Patterns.....	4
Low Battery Detection & Restoral.....	4
<b>INSTALLING THE RADIO .....</b>	<b>5</b>
Removing The Radio's Cover .....	5
Setting The Jumper Options .....	5
Wiring Connections .....	6
Antenna Mounting.....	7
Powering Up .....	9
<b>PROGRAMMING THE 7720V2.....</b>	<b>10</b>
Using A 7720P Programming Tool.....	10
Programming Prompts .....	11
Exiting Program Mode/Setting Defaults.....	16
<b>POST INSTALLATION CHECKLIST.....</b>	<b>17</b>
<b>TESTING THE 7720V2.....</b>	<b>18</b>
<b>TROUBLESHOOTING .....</b>	<b>20</b>
<b>NOTES FOR UL INSTALLATIONS .....</b>	<b>21</b>
<b>SPECIFICATIONS.....</b>	<b>21</b>
<b>CONNECTIONS DIAGRAM .....</b>	<b>23</b>

**Note to the Installer:** Please read these Installation Instructions all the way through and become completely familiar with them before attempting to install a 7720V2 subscriber radio.

# SYSTEM FEATURES & OPERATION

## Introduction

The 7720V2 self-contained subscriber radio is the subscriber end of a Long Range Radio alarm reporting system. As a communications link, the 7720V2 is comparable to a digital communicator connected by telephone line to a central monitoring station.

## System Features

- Wireless Reporting** Alarm and status messages are transmitted to the master station network via radio signals, which means faster and more secure reporting.
- Integrated Electronics** The entire radio link equipment, including interface, transmitter, power supply, battery and antenna, is housed in a single unit, requiring only battery charging power and alarm inputs from a compatible alarm panel.
- Alarm Inputs** The 7720V2 can monitor alarm inputs, discrete 4 zone contact closures or their electrical equivalent.
- Compatibility** The 7720V2 is compatible with existing installations using ADEMCO equipment or other control panels. The 7720V2 can be used in conjunction with digital communicators on the same system, each acting as backup to the another (use an ADEMCO 659-EN Line Monitor connected to a zone input to report a line cut and backup a digital dialer, while connecting the radio fault output to a zone on the dialer).
- Built-in LED Indicators** Three LEDs are used to indicate message transmissions, low battery conditions and radio faults. A blinking yellow LED indicates normal operation. (See LED Table later in this section).
- Built-in Tamper Protection** For added protection, built-in cover tamper switches can trigger an alarm whenever the chassis cover is removed, thus protecting against unauthorized access to the 7720V2. The tamper zone number is an internal system zone number (zones 5-8 can be chosen) and must be programmed to enable tamper reporting.
- Antenna Included** The 7720V2 can use either the supplied omni-directional wire antenna, or can use a 7825 outdoor antenna, 7625 omni-directional antenna, 7625-dB antenna (if additional gain is required), a 7674, a 7674-13 YAGI antenna (if directional antenna is required), by using the optional 7720ANT connector kit. For wall mounting, an optional 7825DP can be used. The supplied antenna mounts directly to the 7720V2. The other antennas can be mounted remotely (if desired) using pre-assembled coaxial cable available from ADEMCO. Refer to the ANTENNA MOUNTING section for details.
- Programmable Features** The 7720V2 utilizes EEROM (Electrically Erasable ROM) technology, which allows the 7720V2 to be programmed with a 7720P Programming Tool. The programming options include channel assignments for Telco fault input, inverted trigger inputs, delayed reporting channels (1-127 seconds delay, if selected; no delay (delay = 00) is allowed for UL installations), open/close/restore reporting channels, etc.
- Self-Diagnosing Transmitter** Malfunctions of the transmitter, including antenna fault, low output power, loss of external power, low internal DC voltage and internal radio-frequency circuit problems can be displayed on the 7720P Programming Tool, as well as being transmitted to the master station network, if the fault does not prevent such transmission. Faults can also trigger contact closures on a Form "C" relay to indicate radio faults.
- Power Supply** The 7720V2 is powered by its own 12 volt battery, which can be charged by an alarm panel's output voltage (9.5-14.8VDC as measured between pins 1 & 2 on the radio). The charging input draws approximately 100mA continuous and 275mA peak current during transmission. If other peripherals are connected to the control panel, make sure the auxiliary charging voltage is calculated and verified with all peripheral at full peak current draw.
- NOTE: The 7720V2TR Power-Pack can be used if there is insufficient charging voltage from the panel.**
- Low Battery Monitoring** The 7720V2 notifies the central station of a low battery condition whenever the battery voltage drops below 10.2VDC ( $\pm 5\%$ ). Low battery restore messages are reported if battery has been in "good" condition for at least 4 hours. Refer to the LOW BATTERY DETECTION AND RESTORAL section for details on battery monitoring.

### Low Battery Shutdown

The 7720V2 automatically shuts down if battery voltage drops below 9.45VDC volts, and ALL LEDs WILL BE OFF. When the charging voltage is present and the battery voltage rises above the 9.45VDC shutdown point, the 7720V2 will enter a BATTERY CHARGING MODE and the RED LED will flash once per second. This mode continues until the battery is sufficiently charged to support alarm conditions. **During the charging cycle, the 7720V2 will not transmit any messages.** The 7720V2 will resume normal operation after the battery is fully charged.

## General Operation

### Alarm Processing

The 7720V2 receives alarm and restore signals from the alarm control panel and converts these signals to radio messages which are transmitted to the master station network, which in turn relays the messages to the central station. The 7720V2 can monitor 4 traditional zone inputs. The first two zones may be configured by jumper to activate on either 0 volts or activate on 4.5-14.2VDC; zones 3 and 4 are hard-wired to activate on 4.5-14.2VDC. Zones 1-4 can also be programmed to invert their input signals.

Upon detecting an alarm or restoral , the 7720V2 transmits the message to the master station network. The transmissions repeat for approximately 6 minutes (total of 60 messages) to ensure that the alarm or other report will be received by the central monitoring station.

The 7720V2 periodically transmits supervisory status messages to the AlarmNet network. Radio faults that are indicated during the status messages may prevent communication; to prevent this, the fault output can be programmed to also indicate radio faults (programming the fault output is explained later in this chapter). If no messages are received during the supervisory window, the network generates a communication failure signal to the central station.

A built-in radio fault contact closure can be used to locally indicate radio faults; this can be either normally open or normally closed. In addition, it can be selected to be "fail-safe" by programming the fault output to be inverted (i.e. the relay is powered unless there is a fault). The radio fault output is labeled TB1-10 and TB1-11 on the terminal strip. These terminals float with reference to the rest of the circuit.

The 7720V2 also provides status information via its serial port, thus allowing radio status to be displayed on command, using either a 7720P Programming Tool or a computer terminal. Refer to the TESTING THE 7720V2 section for information regarding the "S" command and status messages.

### LED Indications

LED	State	Meaning
GREEN	Flash	With YEL solid = Message transmission
YELLOW	Solid Rapid Flash (10 per second) Slow Flash (1/second) Slower Flash  (1 per 3 seconds)	Transmission cycle ON Test or FAST message  Normal operation  Normal, but low battery or DC charging condition detected.
RED	Solid Pattern 1 Flash/Second	Radio Fault detected See Flash Patterns Table Battery charge mode: will continue until the radio senses that the battery is capable of supporting an alarm cycle.
ALL LIT	Consecutive  Slow Unison (2 per second)	Power On/Reset sequence. Repeated twice before entering normal mode. Press [ENTER] during cycle to enter Program Mode.  Radio is not properly programmed. Will continue until [ENTER] is pressed to enter programming mode.

**Radio Fault  
LED Flash Patterns**

#	Flash	Reason
1	S-L-L-L	Internal radio fault
2	S-S-L-L	Power detected when radio should be off
3	S-L-S-L	Full power not attained
4	S-S-S-L	Full power not sustained after transmission
5	S-L-L-S	VSWR is bad
CRC	S-S-L-S	RAM/EEPROM corruption

S=Short flash (150mS); L=Long flash (600mS)  
 #=Fault code number. See "S" command in the TESTING THE 7720V2 section for additional status information.

**Low Battery Detection & Restoral**

(The following features are supported in software versions 2.16 and higher)

**Low Battery Detection** The radio tests the condition of the battery during every transmission. If the battery voltage is low during four consecutive transmissions, yet transmission power is not impaired, a low battery warning message will be transmitted. As long as the transmission power has not been significantly derated, the radio will resume normal operation.

The low battery warning will be restored only after the radio has found the battery to be good during four consecutive transmission **and** a minimum of four hours have elapsed since the radio first detected the battery in the restoral state.

**Entering the  
Battery Charging  
Mode.**

Battery Charging Mode is entered upon either of two conditions:

1. On Power Up, the radio tests the battery to determine whether a transmission can be supported. If the battery fails this initial test, the radio enters Battery Charging Mode.

**NOTE:** Due to this feature the **battery must be plugged in before applying charging voltage during initial power up** to the 7720V2 to prevent it from entering charging mode.

2. During radio transmission, the battery is tested by the 7720V2. If the battery is unable to support a transmission the radio enters Battery Charging mode.

**Condition of Radio  
while in Charging  
Mode**

Upon entering the battery charging mode, the fault relay is tripped, indicating that the radio is inactive. During the Battery Charging Mode, the **Red LED will flash once per second**, the Green and Yellow LED's remain off.

In Charging Mode, the radio is in an idle state for a **minimum of fifteen minutes**. At the end of a fifteen minute cycle time, the radio performs a series of tests on the battery. If all these tests pass, the radio will resume normal operation. If any of these tests fail, the radio will remain idle while it repeats the tests every fifteen minutes until passing.

While in charging mode, the radio will continue to monitor the serial port. The radio will respond only to a reset command from the 7720P (Shift -X). Any other command will result in a display of "BAT CHG" on the 7720P.

**Messages sent  
upon Exiting  
Charging Mode**

Upon exiting the charging mode, the radio will reset the fault relay (if it was latched). If the radio entered charging mode on power up or during the power on reset transmission cycle, the normal power on reset message will be transmitted when charging mode is exited.

If the radio entered charging mode during normal operation, a message indicating a restore of the battery as well as a "restore" of the power on reset (message type 6 with a 3 in both the power on reset position and the battery status position) will be transmitted. This is a unique message which will only be sent on exiting the charging mode (e.g., 5353555 6)

The status of the zones is cleared upon entering the charging mode and is not monitored while in charging mode. Therefore, the only alarm information on any of the zones will be that which is currently on the zone inputs at the time of exiting charging mode (no stale/pending alarms will be sent).

If a zone is currently in alarm, that alarm will be sent after half of the power on reset sequence is transmitted.

# INSTALLING THE RADIO

## Removing The Radio's Cover

Remove the cover by inserting a screwdriver into the 4 removal points at the bottom of the unit and gently releasing the locking tabs from the cover slots as shown.

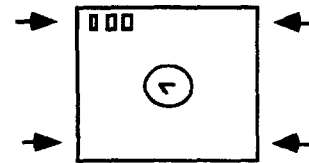

## Setting The Jumper Options (Set Before Installing)

### (J2) Zone Inputs Activate on High or Low

Refer to the diagram below when setting jumpers.

If using zone input connections, set the J2 jumper so that zone 1 & 2 inputs are activated either with a ground or with a positive voltage, whichever is required.

If the trigger level is set for positive voltage, +4.5 to +14.2 volts must be applied to zones 1 & 2 to trigger an alarm. If the zone is connected to a normally high voltage trigger (i.e. goes low on alarm), invert this zone when programming (programming questions 12 & 13).

If ground is selected, zones 1 & 2 are internally pulled up to 5 volts through a 10k ohm resistor. This voltage should normally be pulled down (closed contact to ground) and released for alarm (opening the contact). If a normally open contact is being used, invert this zone when programming (programming questions 12 & 13).

### (J1) Fault Output Select

The radio fault output relay may be programmed for either FAIL-SAFE mode (relay always energized) or LOW CURRENT mode (relay normally de-energized) by selecting Yes or No to programming question 26: FLT REL ON (Y/N). In addition, the relay can be set for either N.O. or N.C. operation (in either fail-safe or low current modes) using the J1 jumper.

When fail-safe mode is selected, the relay will change states (and trigger a dialer, if connected) in the event of power loss. Note that fail-safe mode increases the standby current by about 10mA, which results in lower battery backup time (about 15%) in the event of power loss. Set the J1 jumper to position A or position B, as follows:

Prog. Ques. 26 Fault Relay ON (energized)	J1 Jumper Setting (relay N.O. or N.C.)	
	Pos. B	Pos. A
NO	N.C.	N.O.
YES	N.O.	N.C.

### (J3) ECP/7720P

Use the 7720P position when programming with a 7720P programming tool. The ECP function is not supported by the 7720V2.

### (J4) Trigger Voltage Outputs

This output connector provides for two voltage outputs which are derived from the battery through 1K resistors which are suitable for use with zones 3 and 4 when a dry contact driving device is being used. Connection to this output may be made using the optional Ademco cable, part number 7720TVC.

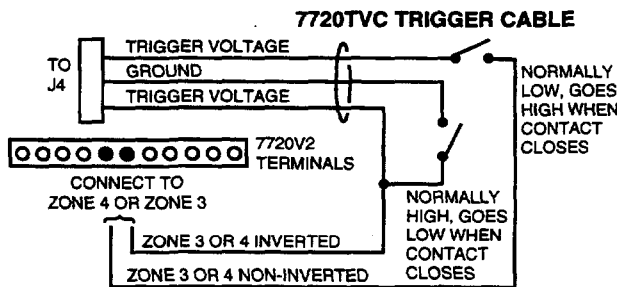

TYPICAL TRIGGER CABLE CONNECTIONS

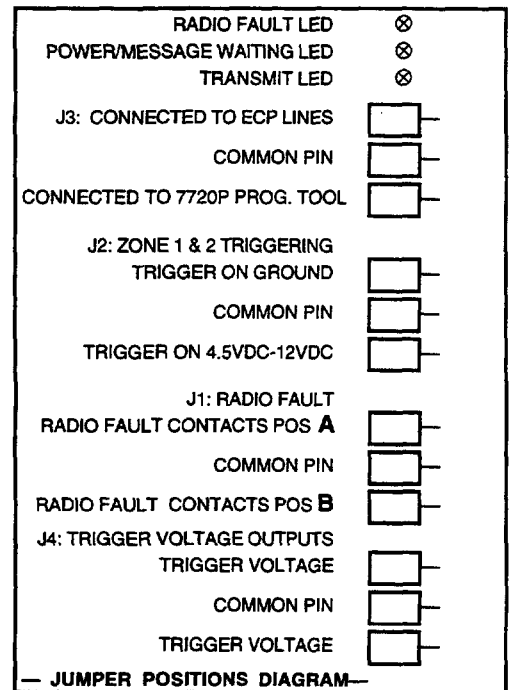

## Wiring Connections

### Wiring At The Control Panel

**NOTE:** Use color-coded wires for the power connections; it is recommended that the positive connection be red and the negative connection be black.

If the auxiliary voltage at the control is between 9.5-14.8 volts and can supply 100mA continuous & 275mA peak, then that output may be used for charging the radio's battery.

1. Connect the negative wire to the system negative point, which is also the negative line from the battery.
2. Run the alarm and power wires to the transmitter location.

**NOTE:** If other peripherals are added to the control, make sure the auxiliary charging capability is calculated and verified with all peripherals at full peak current draw. Failure to do so will result in battery failure.

### Recommended Wiring At The 7720V2

The alarm and power wires can be brought into the transmitter through the base, or through the cover. If they are to be brought through the cover, cut out the optional wire entry port.

1. Connect the positive and negative power wires to TB 1-1 and TB 1-2, respectively.
2. Install the battery into the battery holder, but do not plug in the battery cable yet.

#### Maximum Wire Run Lengths

Gauge	Distance
18	300 feet
20	200 feet
22	125 feet

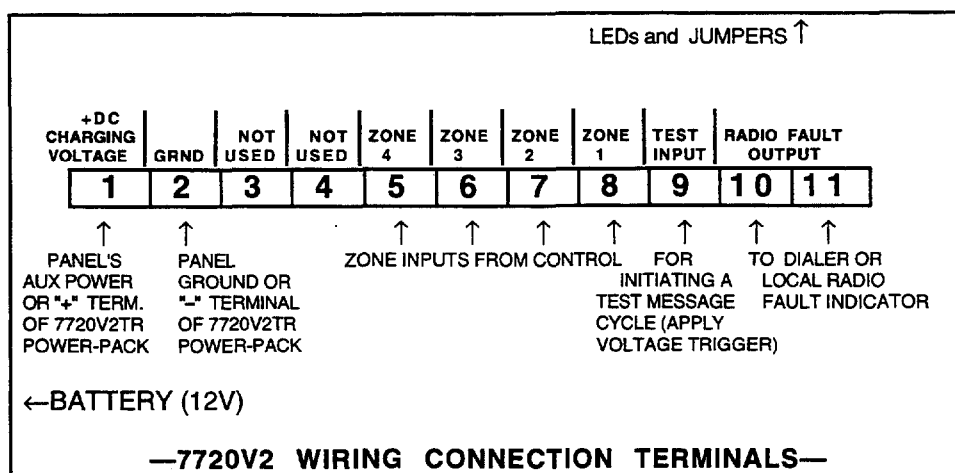

### Mounting the 7720V2

1. Determine the best antenna location for strong radio communication with the Master Station network using the 7915 or 7715 FAST Tool (see ANTENNA MOUNTING section that follows this section).
2. Mount the 7720V2 to a horizontal or vertical surface, depending on the antenna used. Be sure to allow access to the programming port when mounting.

The 7720V2 is intended to be mounted to a horizontal surface, preferably on a ceiling, or in an attic location on top of a joist when using the supplied wire antenna. If using the 7720ANT antenna kit, the 7720V2 can be mounted to a vertical surface such as a wall or beam.

# Antenna Mounting

## Selecting A Location

If **Non UL installation**, an antenna location which has reliable communications with at least one base station with an uplink signal strength reading of "3" or greater may be used .

**NOTE:** Place a check mark [✓] in the "Single Site Supervision" box on the Subscriber Contract.

For **UL Grade "A" or Grade "B" installations**, find an antenna location which has reliable communication to at least two AlarmNet Base Stations with a minimum uplink signal strength reading of "3".

After determining the type of installation required (UL, Non UL ) find an antenna location within the premises. Locations can be found by utilizing the test mode of the 7720V2 (see TESTING THE 7720V2 section), the 7915 or 7715 FAST Tool, or the 7920 series transceiver.

## Notes On Antenna Mounting

1. Optimum RF performance can usually be found at the highest point within a building, with the fewest number of walls between the radio and the outside of the premises.
2. Avoid mounting the antenna near other electronic devices. The following table provides minimum distances. Highest RF energy is in the direct, horizontal line of the antenna. Therefore, vertical separation (moving electronic devices either higher or lower on wall) provides a higher level of isolation from the radio.

Equipment	Distance
Short range receiver	20 ft.
PIR	10 ft.
Control panel	25 ft.
FM radio or TV ant.	25 ft.
other devices	10 ft. minimum

The diagram below displays the 7720V2 mounting options and the appropriate antenna hardware to be used in each of these situations.

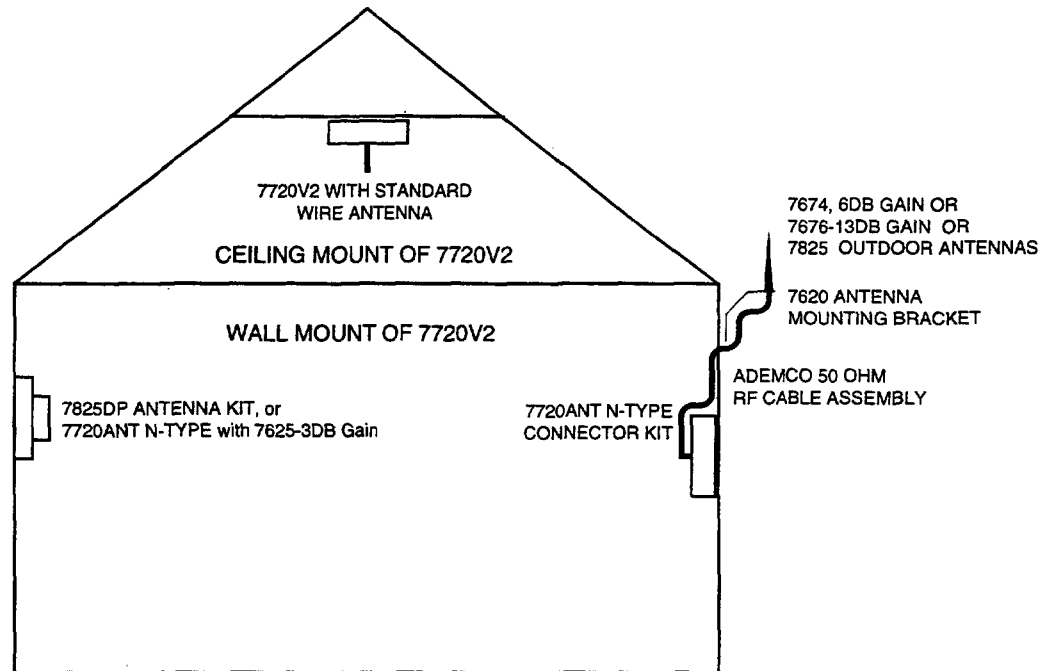

ANTENNA MOUNTING OPTIONS

## Outdoor Antenna Mounting

The 7720V2 must always be mounted indoors. If the only suitable location found is outside of the protected building, mount the 7720V2 close to this location on the **inside** of the building and connect an external (outdoor) antenna to the radio. Carefully follow all instructions included in these optional parts to insure integrity of the weather proof seals on all outside connections. The following antenna kits can be utilized for remote or outdoor mounting.

Antenna	Description
7720 ANT	Adapter for the Remote Antenna
7625-3dB	3dB Gain Antenna
7825	Outdoor Antenna with bracket
7670	Remote Antenna bracket
7674	6dB Gain Direct
7676-13	13dB Gain

## Indoor Antenna Mounting

If the location found allows indoor mounting of the antenna, then the antenna selected depends on the mounting surface of the 7720V2. If it is possible to mount the 7720V2 on a ceiling or on an attic joist, you can use the included wire antenna, which provides excellent performance (see **Standard Wire Antenna Mounting**). If the only mounting surface available is a wall, you can use the 7825DP (see **Wall Mounting**).

### Standard Wire Antenna Mounting

1. Mount the 7720V2 Subscriber Radio on the ceiling or on an attic joist.
2. Replace the 7720V2 cover.
3. Push the antenna into the antenna receptacle until it bottoms out.
4. The antenna should be vertical and straight.
5. Rotate the antenna until it snaps into the locked position. **DO NOT BEND THE ANTENNA!**

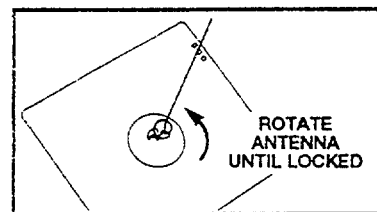

### Wall Mounting using the 7825DP.

1. Mount the radio to a wall or other vertical surface. Make sure the 3 LEDs are in the upper right hand corner.
2. Replace radio's cover.
3. Follow the Installation Instructions included with the 7825DP for mounting to the 7720V2 Subscriber Radio.

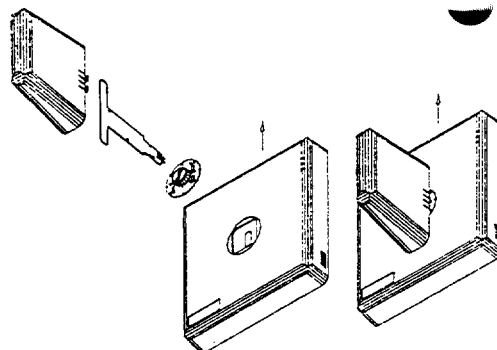

### Wall Mounting with the 7625-3dB Gain and the 7720ANT Adapter.

1. Mount the 7720V2 Subscriber Radio.
2. Replace the radio's cover.
3. Remove the plastic insert from the cover by rotating it 45° counter-clockwise.
4. Replace with the insert provided with the antenna kit.
5. Mount the 7720ANT vertically pointing either up or down, not to the side.
6. Mount the 7625-3DB Gain directly on to the 7720ANT.
7. Mount the plastic bracket (supplied) to the wall 3 inches from the top of the antenna.

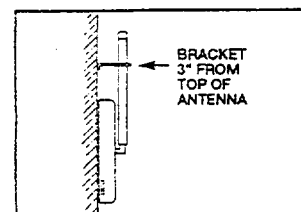
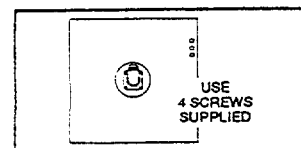
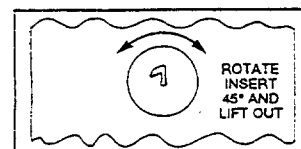



### **Remote Antenna Mounting**

1. Mount the 7720V2 Subscriber Radio.
2. Replace the radio's cover.
3. Mount the 7720ANT directly on to the 7720V2 radio.
4. Mount antenna outdoors in the location determined earlier in this section.
5. Mount the ADEMCO antenna cables.

#### **NOTES:**

1. Use only ADEMCO Cables P/N 7626-5 (5'), 7626-12 (12'), 7626-25LL (25') or 7626-50LL (50').
2. Do not attempt to make the antenna cables yourself, and **do not under any condition try to splice them!**

**For detailed instructions on installing the above antenna kits. Please read the enclosed Installation Instructions.**

### **Powering Up**

1. After all wiring is complete and the unit is mounted, plug the **7720's battery cable** into the connector next to the terminal block,
2. Apply power to the control panel.
3. The LEDs will flash consecutively for a brief time to allow entry into programming mode. If the 7720V2 has been programmed, the LEDs will begin to flash according to their functions. If the 7720V2 has not been programmed, the LEDs will flash in unison indefinitely.

# PROGRAMMING THE 7720V2

## Using A 7720P Programming Tool

- Connection**
1. Set the radio's ECP/7720P jumper to the 7720P position.
  2. Connect the 7720P Programming Tool to the telephone connector on the 7720V2 PC Board. The 7720P Programming Tool is powered by the 7720V2.
  3. After connecting the 7720P cable, power up the 7720V2 (plug in the battery connector and apply power to the control panel). The following will be displayed:

7720V2 xxx  
(c) Pittway 1994

xxx = current software revision level

### 7720P Key Functions

Each key of the 7720P has two possible functions, a normal function and a SHIFT function. To perform a normal key function, simply press the desired key. To perform a SHIFT key function, press SHIFT key, then press desired function key.

Key	Normal Key Function	SHIFT Key Function
BS/ESC	[BS]: Press to delete entry	[ESC]: Press to quit program mode. Also, can reset EEPROM defaults†
↓/↑	[↓]: Scroll down programming	[↑]: Scroll up programming
N/Y	[N]: Press for "NO" answer.	[Y]: Press SHIFT-Y for "YES" answer
SHIFT	Press before pressing a SHIFT key function. Will light SHIFT LED. LED goes out once a key is pressed. Press again for each SHIFT function desired.	
1/A	[1]: For entering the number 1	[A]: Used for entering C.S. ID number
2/B	[2]: For entering the number 2	[B]: Used for entering C.S. ID number
3/C	[3]: For entering the number 3	[C]: Used for entering C.S. ID number
4/D	[4]: For entering the number 4	[D]: Used for entering C.S. ID number
5/E	[5]: For entering the number 5	[E]: Used for entering C.S. ID number
6/F	[6]: For entering the number 6	[F]: Used for C.S. ID & FAST mode
7/S	[7]: For entering the number 7	[S]: Press to display diagnostic status
8/T	[8]: For entering the number 8	[T]: Press to send TEST messages
9/X	[9]: For entering the number 9	[X]: Press to reset the 7720V2
*/SPACE	[*]: Not used with 7720V2	[SPACE]: Not used with 7720V2
0	[0]: For entering the number 0	No SHIFT function
#/ENTER	[#/ENTER]: Press to accept entries	No SHIFT function

† Active only when the "REVIEW?" prompt is displayed.

Programming is accomplished by answering displayed questions. Most questions require only a [Y]es or [N]o response, while others require a numerical response (ID numbers, etc.). Press ENTER to accept each response and proceed to the next question. A "?" indicates an invalid entry. The current value is displayed on the second line in parenthesis (). To accept the current entry, simply press the ENTER key. Use the UP/DOWN arrow keys to scroll through the programming questions without changing any values.

### Entering Program Mode

**Enter programming mode by pressing [ENTER] during the initial power up period (while LEDs are flashing consecutively).**

Pressing SHIFT-X resets the 7720V2 to its initial power up phase if it has already entered program mode. The 7720V2 reads its EEPROM to determine its pre-programmed parameters. A CRC of the EEPROM locations is also read. If the computed CRC does not match the one read from EEPROM or if the programming parameters are invalid, the 7720P LCD displays "NO PROG". While the three LEDs flashes in unison, press ENTER to begin programming. If program mode is entered and the EEPROM contains invalid programming parameters or the CRC is incorrect, the 7720V2 displays:

"EEP ERR/NO PROG"  
"Clear Values?"

Press [Y]es. If [N]o is selected, the 7720V2 displays:

"CANNOT PROCEED"  
"TIL EEP ERASED!"

You must at this time be prepared to program the radio. If the radio was previously programmed using an earlier version of software, it is suggested that you power down the radio, insert the OLD SOFTWARE, and enter programming mode to record the current programming parameters. If the radio configuration is already handy, you need to re-enter programming mode and answer [Y]es to the "CLEAR VALUES?" prompt.

## Programming Prompts

**Password Protection** If desired, the programming menu can be split into two menus by assigning passwords: a central station menu (which contains all programming questions) and a subscriber menu (which contains a subset of the central station menu).

If a password is assigned (for either menu), two menu selection prompts appear upon entering programming mode:

CHOOSE FROM THE  
FOLLOWING MENUS:

Central Sta(1)  
Subscriber (2)

Enter 1 or 2 depending on which menu is to be accessed, then enter the appropriate password when prompted. The first programming question in that menu is then displayed. See EXITING PROGRAM MODE paragraph later in this section for assigning and changing passwords.

### Subscriber Information

Question 1.

ID #

Enter the 4-digit customer account number, 0001-9999.

Question 2.

Central Station Menu.  
See Exiting Program  
Mode, Setting  
Defaults & Assigning  
Passwords for Central  
Station/Subscriber  
Menu Option.

Odd (Y/N)

Enter Y for odd flag (bit value 1), N for even system flag (bit value 0).

Question 3.

Central Station Menu

15 MIN SUPV (Y/N)

The 7720V2 reports its status periodically. Enter the desired reporting interval as follows:  
Y = Short form: every 15 minutes (6-hour window for COM-FAIL report)  
N = Short form: every hour (standard 24 hour reporting for COM-FAIL)

### AlarmNet System Users (Private System users skip to #6)

Question 4.

Central Station Menu

AlarmNet (Y/N)

Enter Y if this is an AlarmNet installation. Enter N if this is a Private System installation (skip to option 6).

Question 5.

Central Station Menu

CS ID

Enter the primary central station's system ID number, 1-7F. Not applicable for Private System users.

### Private System Users (AlarmNet users skip to #8)

Question 6.

Routing Code

Enter the Private System routing code, 0-7. Not applicable for AlarmNet users.

Question 7.

Central Station Menu

Channel #

Enter the Private System channel number, 1-F. Not applicable for AlarmNet users.

**Pulse/Delay Zone Selection**

By configuring a zone as a pulsed zone, it is possible to use the output of a panel bell/siren driver to activate the radio directly when the signal from this driver is a pulsed output for fire and a continuous output for Burglary.

To implement a Fire/Burg. detection at the radio, connect the driver output directly to two zones on the 7720V2. Program the Fire zone as a pulsed zone and the Burglary Zone as a delayed Zone (this is to prevent this zone from reporting an alarm when the pulsed signals are detected). The number of pulses and the length of delay will be dependent on the particular panel or siren driver being used and is therefore a programmable feature.

**Note:** Zones programmed for pulse cannot be designated as open/close or telco zones; an invalid entry message will occur, since the pulse zone takes priority over open/close and telco programmed zones.

- UL Notes:**
1. The 7720V2 is not UL Listed for fire alarm service. Fire reporting is a supplemental use of this product.
  2. For UL installations, questions 8a, 9a, 10a and 11a that follow should be programmed NO (N) for the Pulse option and the delay (questions 8b, 9b, 10b and 11b) should be 00.

Question 8a.

**Pulse Z1 (Y/N)**

Press Y if zone 1 is connected to a pulsed bell output. Question 8c will appear. If N is pressed, the following appears.

Question 8b.

**Z1 Delay (00-127)**

Enter the reporting delay from 1-127 seconds for zone 1. Enter 00 for no reporting delay.

Question 8c.

**Pulse Cnt (03)**

If Pulsed Zone is answered Y, enter the number of pulses 1-127 required to place the zone in alarm. Default is (03).

Question 9a.

**Pulse Z2 (Y/N)**

Press Y if zone 2 is connected to a pulsed bell output. Question 9c will appear. If N is pressed, the following appears.

Question 9b.

**Z2 Delay (00-127)**

Enter the reporting delay from 1-127 seconds for zone 2. Enter 00 for no reporting delay.

Question 9c.

**Pulse Cnt (03)**

If Pulsed Zone is answered Y, enter the number of pulses 1-127 required to place the zone in alarm. Default is (03).

Question 10a.

**Pulse Z3 (Y/N)**

Press Y if zone 3 is connected to a pulsed bell output. Question 10c will appear. If N is pressed, the following appears.

Question 10b.

**Z3 Delay (00-127)**

Enter the reporting delay from 1-127 seconds for zone 3. Enter 00 for no reporting delay.

Question 10c.

**Pulse Cnt (03)**

If Pulsed Zone is answered Y, enter the number of pulses 1-127 required to place the zone in alarm. Default is (03).

Question 11a.

**Pulse Z4 (Y/N)**

Press Y if zone 4 is connected to a pulsed bell output. Question 11c will appear. If N is pressed, the following appears.

Question 11b.

**Z4 Delay (00-127)**

Enter the reporting delay from 1-127 seconds for zone 4. Enter 00 for no reporting delay.

Question 11c.

**Pulse Cnt (03)**

If Pulsed Zone is answered Y, enter the number of pulses 1-127 required to place the zone in alarm. Default is (03).

**Inverted Zone Selection**

Zones 1-4 and the test zone can be programmed to trigger upon inverted input signals. Normally, input signals are "low" and alarms are triggered when the input signal goes "high." If the inverted option is selected, input signals are "high" and alarms are triggered when the input signal goes "low."

- Question 12.  **Invert Z1 (Y/N)** Press Y to invert the input signal for zone 1. Press N for normal input signal.
- Question 13.  **Invert Z2 (Y/N)** Press Y to invert the input signal for zone 2. Press N for normal input signal.
- Question 14.  **Invert Z3 (Y/N)** Press Y to invert the input signal for zone 3. Press N for normal input signal.
- Question 15.  **Invert Z4 (Y/N)** Press Y to invert the input signal for zone 4. Press N for normal input signal.
- Question 16.  **Invert Test(Y/N)** Press Y to invert the input signal for the test zone. Press N for normal input signal.

**Restoral Reporting Zone Selection**

Restoral reporting can be enabled, disabled or delayed. The delay option delays restoral reporting for about 1.5 minutes after the actual restore condition, which helps ensure that alarm messages reach the central station before the restore message. Note that if restores are enabled for a delayed zone, the restore condition must exist for at least 2.5 seconds (this is intended to prevent swinger conditions). If any of the zones have been programmed for pulse operation, then, following the Restoral question, the 7720P will display "REST ON CHG (Y/N)". This feature is used for zones connected to the bell output of a panel, and when enabled (Y) will report the zone in restoral when the pulse train stops and a steady state level, either high or low, is left on the zone input or when the steady state level starts pulsing. If this feature is not enabled (N), the zone will only restore on a steady state low logic level.

**UL NOTE:** For UL installations, restorals must not be disabled.

- Question 17.  **Rest. Z1 (Y/N/D)** Press Y to enable restoral reporting for zone 1. Press N to disable restoral reporting. Press D for delayed reporting.
- Question 17a  **Rest. On CHG (Y/N)** Press Y if restore is to be sent when the type of signal changes (i.e., when pulsing state changes to a steady state level [high or low] or when a steady state changes to a pulsing state). Press N for restore to occur when the opposite steady state occurs (e.g., when a steady state high goes low).
- Question 18.  **Rest. Z2 (Y/N/D)** Press Y to enable restoral reporting for zone 2. Press N to disable restoral reporting. Press D for delayed reporting.
- Question 18a  **Rest. On CHG (Y/N)** Press Y if restore is to be sent when the type of signal changes (i.e., when pulsing state changes to a steady state level [high or low] or when a steady state changes to a pulsing state). Press N for restore to occur when the opposite steady state occurs (e.g., when a steady state high goes low).
- Question 19.  **Rest. Z3 (Y/N/D)** Press Y to enable restoral reporting for zone 3. Press N to disable restoral reporting. Press D for delayed reporting.
- Question 19a  **Rest. On CHG (Y/N)** Press Y if restore is to be sent when the type of signal changes (i.e., when pulsing state changes to a steady state level [high or low] or when a steady state changes to a pulsing state). Press N for restore to occur when the opposite steady state occurs (e.g., when a steady state high goes low).

- Question 20. **Rest. Z4 (Y/N/D)** Press Y to enable restoral reporting for zone 4. Press N to disable restoral reporting. Press D for delayed reporting.
- Question 20a **Rest. On CHG (Y/N)** Press Y if restore is to be sent when the type of signal changes (i.e., when pulsing state changes to a steady state level [high or low] or when a steady state changes to a pulsing state). Press N for restore to occur when the opposite steady state occurs (e.g., when a steady state high goes low).

**Open/Close, Telco & Tamper Zone Selection** The following prompts program miscellaneous options.

- Question 21. **O/C Zone** Enter the open/close reporting zone number, 1-4. Enter 0 to disable open/close reporting. If the zone selected was programmed to be a pulse zone, (see Questions 8-11), this zone number selection is invalid and will be tagged as an error.
- Question 22. **Telco Chan** Enter the physical telco line fault zone, 1-4. Enter 0 to disable telco detection. **If this zone is the same as the open/close zone, this selection will automatically be set to "0" and telco detection will be disabled.** If the zone selected was programmed to a pulse zone (see Questions 8-11) this zone number selection is invalid and will be tagged as an error. Telco channel must be enabled for UL installations.
- Question 23. **Tamper zone** Enter tamper zone, 5-8 (these are internal system zone numbers reserved for tamper reporting). Enter 0 to disable tamper detection. If tamper is enabled, delayed restores will be automatically generated. Tamper zone must be enabled for UL installations.
- Question 24. **HS Ant. Tst (Y/N)** Press Y for 135 second interval antenna test. Press N if no antenna test is desired. Must be YES (Y) for UL installations.
- Question 25. **DC Loss RPT (Y/N)** Press Y, to have the radio report the loss of DC charging voltage within a 10 to 40 minute window from its detection. Press N to disable this feature (this message will be suppressed). Must be YES (Y) for UL installations. **NOTE:** In either case, low battery messages will be sent as detected.
- Question 26. **FLT REL ON (Y/N)** Press Y if fail-safe mode is desired. In this mode, the fault relay is normally energized and will de-energize in the event of a radio fault. Note that fail-safe mode draws slightly more standby current. See the SETTING THE JUMPERS section for setting the relay output. Must be YES (Y) for UL installations. Press N if not desired.
- Question 27. **Flt Latched(Y/N)** Press Y if radio fault line is to be latched high upon detection of transmission error. Press N if a momentary closure upon detection of transmission error is desired. Must be YES (Y) for UL installations.

**Redundant Central Station Reporting**

- |              |                          |  |
|--------------|--------------------------|--|
| Question 28. | <b>2nd CS (Y/N)</b>      | Press Y if redundant reporting to a second central station is desired. Press N if not desired (skip to end).   |
| Question 29. | <b>2CS Z1 (Y/N)</b>      | Press Y to enable zone 1 reporting to second central station. Press N to disable reporting.  |
| Question 30. | <b>2CS Z2 (Y/N)</b>      | Press Y to enable zone 2 reporting to second central station. Press N to disable reporting.  |
| Question 31. | <b>2CS Z3 (Y/N)</b>      | Press Y to enable zone 3 reporting to second central station. Press N to disable reporting.  |
| Question 32. | <b>2CS Z4 (Y/N)</b>      | Press Y to enable zone 4 reporting to second central station. Press N to disable reporting.  |
| Question 33. | <b>2CS Test (Y/N)</b>    | Press Y to enable test reporting to second central station. Press N to disable reporting.  |
| Question 34. | <b>2CS Tamp (Y/N)</b>    | Press Y to enable tamper reporting to second central station. Press N to disable reporting.  |
| Question 35. | <b>2CS Sys Rpt (Y/N)</b> | Press Y to enable reporting of system report to second central station. Press N to disable reporting.  |
| Question 36. | <b>2nd ID #</b>          | Enter the 4-digit customer account number for the second central station, 0001-9999.   |
| Question 37. | <b>2nd CS ID</b>         | Enter the second central station's system ID number, 1-7F. This ID number must be different from the one programmed in question 5 (the Primary CS ID). |

## Exiting Program Mode, Setting Defaults & Assigning Passwords

When the last question is answered, all entries are validated by the system. If no errors are found, the following is displayed:

**REVIEW?**

To review the programming options (to ensure that the correct responses have been made), press Y. The programming questions will be displayed again, starting with question 1. Use the UP/DOWN arrow keys to scroll through the program fields without changing any of the values. If a value requires change, simply type in the correct value. When the last field is displayed, the REVIEW? question again appears.

If errors are found during the validation routine (values are out of range or there is a conflict of parameters), the REVIEW? question is replaced by the following:

**ERRORS FOUND  
HIT ANY KEY**

Upon hitting any key, the first invalid entry is displayed. Correct the entry then press ENTER to display the next invalid entry. When the last invalid entry is corrected, the system again performs a validation routine. If no errors are found, the REVIEW? question is displayed.

To display all program entries (not only invalid entries) press the up arrow key. The previous question appears. Use the down arrow key to display subsequent programming entries.

**Setting Factory Defaults:** The programming options can be globally reset to their factory default values by pressing ESC at the REVIEW? prompt. A confirmation prompt will appear. Press Y to reset, or press N to return to the REVIEW? prompt. If Y is pressed, all programmed values will be reset to their original factory settings.

To exit program mode & assign passwords, press N in response to the REVIEW? question. If no password has been assigned, the following appears:

**ENTER PASSWORD?  
[Y/N]**

Passwords can be used to split the programming questions into two menus. See PASSWORD PROTECTION paragraph earlier in this section. If a password is desired, press Y. The following prompts appear. Press N if no passwords are desired.

**CHOOSE FROM THE  
FOLLOWING MENUS:**

**Central Sta(1)  
Subscriber (2)**

Enter 1 or 2 depending on the menu to which a password is to be assigned. When prompted, enter the desired password (up to 4-digits max.) . You will then be prompted to reenter it (as confirmation).

**NOTE:** If using a terminal to program passwords, use only those characters available on the 7720P to allow later access using a 7720P (A, B, C, D, E, F, S, T, X).

If a password has already been assigned for the current programming menu, the ENTER PASSWORD? prompt is replaced by the following:

**CHG PASSWORD?  
[Y/N]**

Press Y or N, depending on whether you want to change the password for the **current** programming menu. If [Y]es, you will be prompted to enter the new password twice (as confirmation). To clear an existing password, answer "Y" to the "change password" prompt, but press only the ENTER key when prompted for the new password and its confirmation.

When the password question(s) have been answered, the system exits program mode and returns to normal mode. The Programming Tool can then be disconnected, or can be used to trigger test messages. Refer to the TESTING THE 7720V2 section.



## POST INSTALLATION CHECKLIST

Post Installation Checklist is intended for installers who want to get the 7720V2 up and running quickly.

To take full advantage of the many installation features of 7720V2, we strongly suggest you take a few moments and read the programming section.

DC Charging Voltage	Make sure that there is sufficient power to charge and support the current draw of the 7720V2 (9.5 VDC Minimum, 14.8VDC maximum, 100mA normal standby, 275mA maximum). <b>Note:</b> Additional peripherals connected to the control may lower available current for the radio and affect the battery current draw level. The auxiliary voltage charging capability must be calculated and verified with all peripherals at full peak current draw.
Battery Fully Charged	The 7720V2 is fully dependent on the battery for reliable communication. Make sure the battery is fully charged at 13.6 volts. If voltage is less than 11 volts, the 7720V2 will not operate.
Power-Up	Always connect the battery first.
Weather Proofing	All outside antennas and cable connections must be weatherproofed.
Antenna Positioning	Make sure the 7625 antenna is vertically mounted. If installing the 7625 or 7674 antenna outside, use the 7670 Antenna Bracket and follow the installation instructions enclosed.

## TESTING THE 7720V2

### Radio Transmission Test

The 7720V2 is capable of sending a test message, which can be received by the central station to confirm the radio's communication link to the central station.

For AlarmNet users, the test message will cause the master station network to send a "Field Triggered Diagnostic Message" to the central station. This message provides network information as well as signal strength and frequency characteristics of the transmitted messages. Refer to the AlarmNet User's Guide for detailed information concerning these messages. The test message can be transmitted in any of three ways.

1) The TEST INPUT (terminal 9) of the 7720V2 can be triggered with a voltage trigger, which will initiate a 90 second cycle (total of 60 messages) of test message transmissions. Note that once this cycle has been initiated by a voltage trigger, it can be turned off by using the T command described in (2). Otherwise, the messages will not stop until the end of the cycle.

2) A 7720P Programming Tool can be used, if connected to the programming connector of the 7720V2. To begin a cycle of test message transmissions, press SHIFT-8 (T command). This is a toggle function. To end the transmissions before the end of the cycle, simply enter the command again.

3) A computer terminal can be used, if connected to the programming connector of the 7720V2. To begin a cycle of test message transmissions, press SHIFT-8 (T command). This is a toggle function. To end the transmissions before the end of the cycle, simply repeat the command.

### System Test

Trigger an alarm by any convenient means and observe the LED indicators on the radio. The yellow LED should light solidly, followed by the green LED flashing every 1-3 seconds at first, then slowing during the 6 minute cycle. This indicates that an alarm message has been received at the radio (yellow), and the transmitter has been activated (green). The red LED should not light.

If the zone is programmed for restore, restore the circuit. The yellow LED should light solidly and the green LED should flash again, indicating transmission of the restore message. The central station receiver should display alarm/restore messages for each triggered alarm/restore performed.

If at any time the red LED lights, a radio fault has been detected. This could be caused by a faulty antenna connection, or might be caused by low internal battery voltage, or a failure in the radio's power circuits (see LED FLASH PATTERNS on page 4). The 7720P can display diagnostic data ("S" command) related to the status of these conditions. See Status Command section.

Replace the cover (if it was removed) and perform a control panel system test.

### Last Detected Fault "E" Command

The last detected radio fault and the last reported radio fault can be viewed by pressing "E" on a 7720P Programming Tool or an appropriate terminal when either device is connected to the serial port of the 7720V2.

The message is a 2-line display where the top line identifies the last fault that the 7720V2 detected and the second line identifies the last fault that the 7720V2 actually reported to the monitoring network. The **last detected fault** represents a fault that occurred on at least one transmission, but did not necessarily trip the fault relay. The **last reported fault** is a fault that was present for a number of transmissions (typically at least 4 consecutive transmissions) and which tripped the fault relay. The possible fault numbers are described in the "S" command paragraph above. If the detected fault does not match the reported fault value, and the transmission cycle has finished, it indicates that the fault was not present long enough for the radio to report the condition.

These values are stored in EEPROM and will be retained even when the 7720V2 is powered down. To erase the numbers from memory, press ESC (shift BS) as the next keystroke after pressing "E". The fault value is also erased automatically upon exiting program mode.

**NOTE:** Since the execution of this command requires access to the RJ11 connector, the antenna and cover must be removed. By doing so, the radio will detect an RF fault as well as a tamper. To prevent this fault from overwriting a previous fault, the radio does not write the last reported fault to EEPROM if a tamper is detected.

**Status "S" Command** The status of the 7720V2 can be viewed on either a 7720P Programming Tool or an appropriate terminal when either device is connected to the serial port of the 7720V2. The status display includes zone input status, test terminal status, tamper status, battery condition, charging voltage status and radio fault status. The 2-line display takes the following form:

1234TeTmBaDcFlt
5555 5 5 + + 0

**1 2 3 4** The numbers 1-4 represent the four zone inputs, and follow Ademco High Speed Format codes:

- 1 New Event
- 2 New Opening
- 3 Restore
- 4 New Closing
- 5 Normal
- 6 Previously Reported Event
- @ Telco New Event
- P Telco Previously Reported
- p Telco Restore

**Te** Test terminal input codes:

- 1 Test message transmission in progress, triggered by either physical test point or "T" command.
- 5 Normal (no test message in progress).
- 6 Transmission of test message completed, but physical test point still triggered.
- P Transmission of test message pending completion of higher priority message transmission.

**Tm** Tamper status follows High Speed Format codes above.

**Ba** Represents battery condition:

- + Battery voltage acceptable
- Battery voltage below 10.8V  $\pm 5\%$
- V Battery voltage going low has not yet been detected low for four consecutive transmissions
- ^ Battery restoring, but not yet reported as restored

**Dc** Represents charging voltage:

- + DC charging voltage OK
- DC charging voltage bad & reported
- V DC charging voltage bad, not reported (reporting window not expired)
- ^ DC charging voltage restored, not reported as restored

**Flt** Represents Radio Faults. See LED flash patterns described earlier in this manual.

- 0 Normal
- 1 Internal radio fault\*
- 2 RF power detected without a valid transmission\*.
- 3 Forward power never attained\*\*
- 4 RF power not sustained throughout transmission\*\*.
- 5 VSWR bad (check antenna, connections and cable)

**CRC** Ram/EEPROM corruption. Reset the radio and if necessary reprogram. If this fault recurs, return radio for service.

\* Codes 1 & 2 require factory service.

\*\* Codes 3 & 4 could be the result of a bad or discharged battery. If battery is found to be OK, the unit requires factory service.

# TROUBLESHOOTING

Problem	Probable Cause	Solution
No signals received	7720V2 in Charging Mode	Replace or Charge Battery
	Incorrect power-up procedure	Plug-in the battery first.
	Antenna Location	See page 15-16 for selecting Antenna locations.
	Programming (Subscriber #, Central Station ID #, or O/E)	Verify and correct programming entry.
	Radio Fault	If you have a 7720P, see page 20 If you don't have a 7720P, see page 4 (LED FLASHING).
	Low Battery	Confirm charging voltage at Pins 1 & 2. Replace battery.
Low Battery	Charging Source	The 7720V2 needs a constant charging source of 100mA and 275mA at peak with a minimum of 9.5VDC charging voltage. Problems will be displayed on the 7720P. If current charging source is not adequate to supply the 7720V2, use the ADEMCO 7720V2TR Power Pack.
	Auxiliary Voltage	If not providing 9.5 volts-14.2 volts, use ADEMCO 7720V2TR Power Pack.
	Environment	If temperature exceeds -30°C to 60°C, this will diminish battery capacity and or life. Replace battery if required.
		Relocate the 7720V2 by using the Remote Antenna Kit.
Central Station is not receiving Alarms.	No ground connection	Connect common ground from trigger output (TB Pin 2).
	Incorrect trigger input.	Verify type of input. Application of +4.5 to 12 volts (Non-Inverted). Absence of +4.5 to 12 volts (Inverted).
	Incorrect Jumper settings.	See Setting the Jumper Options: J2 Zone Input J3 ECP Operation J4 Trigger Voltage

## SPECIAL NOTES FOR U.L. INSTALLATIONS

The 7720V2 Remote Subscriber Unit can be used in systems Listed by Underwriter's Laboratories for Grade A and Grade B Central Station Mercantile Burglary. The following additional requirements must be observed for the installation of subscriber remote equipment in such systems:

1. Installation must be in accordance with the National Electrical code and UL611.
2. The 7720V2 is intended to be connected to dry contact and voltage trigger outputs of a Listed compatible control unit.
3. The 7720V2 must be programmed as follows:
  - a) This product is not Listed for Fire Alarm Service. Therefore, zones should not be programmed as pulsed (programming questions 8a, 9a, 10a, 11a).
  - b) Delayed reporting should be programmed as 00 (programming questions 8b, 9b, 10b, 11b).
  - c) Restoral reporting must not be disabled (programming questions 17, 18, 19, 20).
  - d) The Telco channel must be enabled. Do not enter 0 (programming question 22).
  - e) A tamper zone must be enabled (programming question 23). The tamper switch shall be enabled and mapped to a 7720V2 zone.
  - f) The High Security Antenna Test option must be programmed as YES (programming question 24). The default is once every 135 seconds.
  - g) DC Loss Reporting must be programmed as YES (programming question 25).
  - h) The Fault Relay On option must be programmed as YES (programming question 26).
  - i) The Fault Relay Latched option must be programmed as YES (programming question 27).
4. **FOR GRADE A CENTRAL STATION INSTALLATIONS:** A UL Listed communicator must monitor the radio fault output (terminals 10 & 11) of the 7720V2. A No. 659EN Telco Line Monitor's output should be connected to an input zone of the 7720V2 unit. The 659EN shall be inside the control enclosure. Premises openings and closings should be sent via the communicator. The fault relay (question 26) shall be programmed as fail-safe (fault relay ON) and jumper J1 shall be set in "A" position (normally closed). In addition, the installation must meet the requirements defined for GRADE B CENTRAL STATION INSTALLATIONS defined below.
5. **FOR GRADE B CENTRAL STATION INSTALLATIONS:** All wiring between the 7720V2 and the Listed control panel must be enclosed in rigid conduit (outside walls) or flexible conduit (inside walls or above ceilings). The door and any windows in this room shall be protected by a UL Listed intrusion detection device. The fault relay shall be monitored by a trouble zone of the control unit. The control unit shall be a Listed Grade A Local Burglar Alarm Unit/Police Connect Unit.
6. **FOR POLICE STATION CONNECTED INSTALLATIONS:** Same requirements as for GRADE B CENTRAL STATION INSTALLATIONS defined above, except that the control panel must be Listed for GRADE A POLICE CONNECT.
7. All wiring not run in conduit shall be contained within the same room as the 7720V2.

## SPECIFICATIONS

Dimensions:	8.5" x 9.5" x 1.7".
Power:	9.5-14.8VDC, supplied from alarm panel or other DC power supply.
Current drain:	Normal standby = 100 mA Maximum = 275 mA
Battery:	Ademco 7720BT, 12VDC, 800 mAH
Fuse:	3 A (ADEMCO No. 90-12)
Fault Relay Output:	30V, 1A
Trigger Voltage Outputs:	typically 12.8VDC (battery voltage isolated through an on board, 1k series resistor)
Input triggering levels:	Zones 1 & 2: selectable 0 volts or 4.5 to 14.2 volts into 10k ohms Zones 3 and 4: 4.5 to 12 volts into 10k ohms
RF power output:	5 watts nominal
Frequency band:	928.0125 MHz to 928.3375 MHz, 25 KHz channels
Frequency accuracy:	± 5 PPM.
Operating temp:	-30 to +60 deg. Celsius.
Storage temp:	-40 to +70 deg. Celsius.
Humidity:	90% relative humidity, non-condensing
Altitude:	to 10,000 ft. operating, to 40,000 storage.
Antenna:	Integral 5/8 wave whip. Optional external Type N connector

### **FEDERAL COMMUNICATIONS COMMISSION (FCC) STATEMENT**

This equipment has been tested to FCC requirements and has been found acceptable for use. The FCC requires the following statement for your information:

This equipment generates and uses radio frequency energy and if not installed and used properly, that is, in strict accordance with the manufacturer's instructions, may cause interference to radio and television reception. It has been type tested and found to comply with the limits for a Class B computing device in accordance with the specifications in Part 15 of FCC Rules, which are designed to provide reasonable protection against such interference in a residential installation. However, there is no guarantee that interference will not occur in a particular installation. If this equipment does cause interference to radio or television reception, which can be determined by turning the equipment off and on, the user is encouraged to try to correct the interference by one or more of the following measures:

- If using an indoor antenna, have a quality outdoor antenna installed.
- Reorient the receiving antenna until interference is reduced or eliminated.
- Move the receiver away from the transmitter.
- Move the antenna leads away from any wire runs to the transmitter.
- Plug the transmitter into a different outlet so that it and the receiver are on different branch circuits.

If necessary, the user should consult the dealer or an experienced radio/television technician for additional suggestions.

The user or installer may find the following booklet prepared by the Federal Communications Commission helpful:

"Interference Handbook"

This booklet is available from the U.S. Government Printing Office, Washington, DC 20402.

The user shall not make any changes or modifications to the equipment unless authorized by the Installation Instructions or User's Manual. Unauthorized changes or modifications could void the user's authority to operate the equipment.

### **TO THE INSTALLER**

Regular maintenance and inspection (at least annually) by the installer and frequent testing by the user are vital to continuous satisfactory operation of any alarm system.

The installer should assume the responsibility of developing and offering a regular maintenance program to the user as well as acquainting the user with the proper operation and limitations of the alarm system and its component parts.

Recommendations must be included for a specific program of frequent testing (at least weekly) to insure the system's proper operation at all times.

### **THE LIMITATIONS OF THIS RADIO COMMUNICATIONS SYSTEM**

While this 900 MHz Long Range Radio communications system is part of an advanced and sophisticated security system, it does not offer guaranteed protection against burglary or fire, nor does it guarantee communication of burglary or fire warning signals to a central station. Any alarm system, or any communications system, whether commercial or residential, is subject to compromise, or failure to warn, for a variety of reasons. Examples of some of these reasons are:

- Intruders may gain access through unprotected openings or have technical sophistication to bypass an alarm sensor, and then disconnect an alarm communicating radio transmitter.
- Signals sent by 900 MHz radio transmitters may be blocked by metal, mountains, hills, foliage and other natural and man made obstructions before they are received by a master receiving station or sent to a central station. Even a path previously verified as acceptable may periodically change its characteristics.
- Long-range radio communication transmitters will not work without power. Radio transmitters require a battery to work properly in the absence of A.C. power. A weak or dead battery, or improperly installed batteries may prevent these devices from functioning properly if A.C. power is disrupted for any reason.
- Radio communication systems are subject to external interference, natural or man-made, intentional or coincidental, that may keep a signal or group of signals from being successfully received by a master receiving station or a central station. In addition, one-way radio communication devices receive no acknowledgment from a master receiving station that their signals are being successfully received. Signals transmitted may clash with those transmitted from other systems. While statistical estimates predict successful operation, if the guidelines in the system manuals are followed, the operation of this system is still probabilistic in nature and may be subject to random signal failures.
- Radio communication devices may change their characteristics over time. Such parameters as frequency, modulation and power should be properly monitored periodically, with required adjustments made by qualified personnel.
- Radio communication devices must be installed by qualified personnel. Improper installation or selection of a transmitter's location may cause intermittent or unreliable performance.

Any electronic or mechanical device can fail. The most common cause of an alarm system or a radio communications system not functioning properly when an intrusion or fire occurs is inadequate maintenance, maintenance that is intended to find such failures as soon as possible. This alarm and communication system should be tested weekly to be sure all sensors and transmitters are working properly.

Installing an alarm system may make one eligible for lower insurance rates, but an alarm system is not a substitute for adequate insurance. Homeowners, property owners, business owners and renters should continue to insure their property and lives.

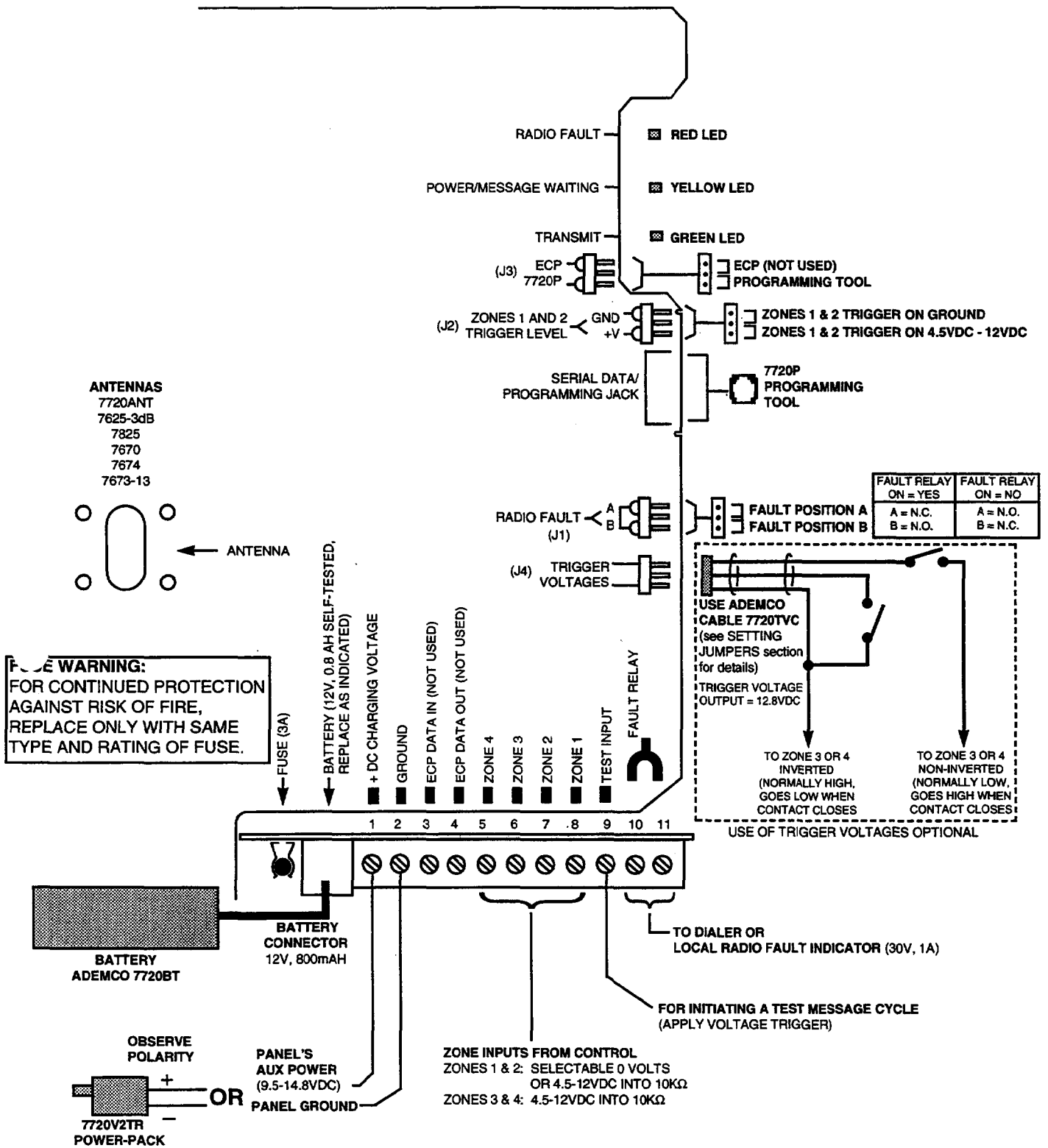

## 7720V2 SUMMARY OF CONNECTIONS DIAGRAM

## **ADEMCO LIMITED WARRANTY**

Alarm Device Manufacturing Company, a Division of Pittway Corporation, and its divisions, subsidiaries and affiliates ("Seller"), 165 Eileen Way, Syosset, New York 11791, warrants its products to be in conformance with its own plans and specifications and to be free from defects in materials and workmanship under normal use and service for 18 months from the date stamp control on the product or, for products not having an Ademco date stamp, for 12 months from date of original purchase unless the installation instructions or catalog sets forth a shorter period, in which case the shorter period shall apply. Seller's obligation shall be limited to repairing or replacing, at its option, free of charge for materials or labor, any product which is proved not in compliance with Seller's specifications or proves defective in materials or workmanship under normal use and service. Seller shall have no obligation under this Limited Warranty or otherwise if the product is altered or improperly repaired or serviced by anyone other than Ademco factory service. For warranty service, return product transportation prepaid, to Ademco Factory Service, 165 Eileen Way, Syosset, New York 11791.

THERE ARE NO WARRANTIES, EXPRESS OR IMPLIED, OF MERCHANTABILITY, OR FITNESS FOR A PARTICULAR PURPOSE OR OTHERWISE, WHICH EXTEND BEYOND THE DESCRIPTION ON THE FACE HEREOF. IN NO CASE SHALL SELLER BE LIABLE TO ANYONE FOR ANY CONSEQUENTIAL OR INCIDENTAL DAMAGES FOR BREACH OF THIS OR ANY OTHER WARRANTY, EXPRESS OR IMPLIED, OR UPON ANY OTHER BASIS OF LIABILITY WHATSOEVER, EVEN IF THE LOSS OR DAMAGE IS CAUSED BY THE SELLER'S OWN NEGLIGENCE OR FAULT.

Seller does not represent that the products it sells may not be compromised or circumvented; that the products will prevent any personal injury or property loss by burglary, robbery, fire or otherwise; or that the products will in all cases provide adequate warning or protection. Customer understands that a properly installed and maintained alarm may only reduce the risk of a burglary, robbery, fire or other events occurring without providing an alarm, but it is not insurance or a guarantee that such will not occur or that there will be no personal injury or property loss as a result. CONSEQUENTLY, SELLER SHALL HAVE NO LIABILITY FOR ANY PERSONAL INJURY, PROPERTY DAMAGE OR OTHER LOSS BASED ON A CLAIM THE PRODUCT FAILED TO GIVE WARNING. HOWEVER, IF SELLER IS HELD LIABLE, WHETHER DIRECTLY OR INDIRECTLY, FOR ANY LOSS OR DAMAGE ARISING UNDER THIS LIMITED WARRANTY OR OTHERWISE, REGARDLESS OF CAUSE OR ORIGIN, SELLER'S MAXIMUM LIABILITY SHALL NOT IN ANY CASE EXCEED THE PURCHASE PRICE OF THE PRODUCT, WHICH SHALL BE THE COMPLETE AND EXCLUSIVE REMEDY AGAINST SELLER. This warranty replaces any previous warranties and is the only warranty made by Seller on this product. No increase or alteration, written or verbal, of the obligations of this Limited Warranty is authorized.



**ALARM DEVICE MANUFACTURING CO.**  
A DIVISION OF PITTPWAY CORPORATION  
165 Eileen Way, Syosset, New York 11791  
Copyright© 1993 PITTPWAY CORPORATION