

MODEL 2180

8 ZONE DIGITAL CONTROL ANNUNCIATOR

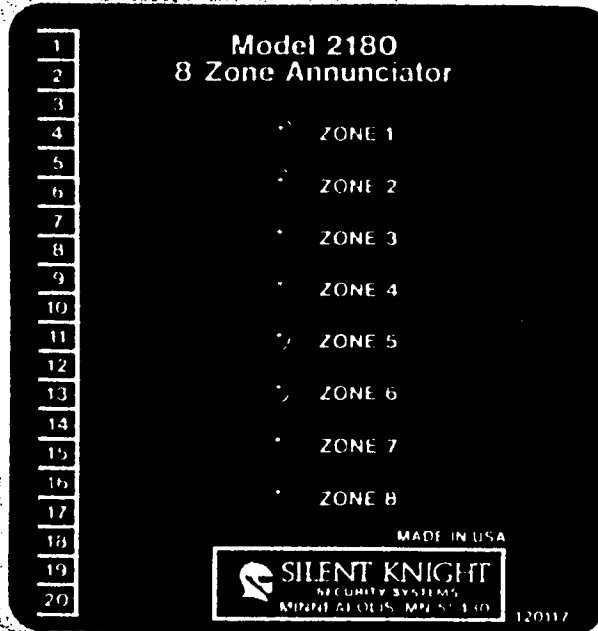

INSTALLATION MANUAL



**SILENT
KNIGHT**

SECURITY SYSTEMS

Division of Waycrosse, Inc.
7550 Meridian Circle • Minneapolis, MN 55369-4927

P/N 150108

MODEL 2180
(Installation Manual)

DESCRIPTION

The Model 2180 is designed to expand an Alarm Control panel by up to eight additional zone inputs.

The 2180 provides visual indication of:

- Zones not "READY" to be armed (Zone LED is on).
- Zones which have been shunted or bypassed. (LED blinking system not armed)
- Zones which have caused an alarm. (LED blinking - system armed)

In addition the Model 2180 will provide individual zone shunting from the digital key remote modules.

The 2180 is connected to the control panel and key modules (Models 2080 or 7480) and the loop circuits by a 20 position terminal strip and a 12 pin connector.

TERMINAL STRIP

Terminals 1 through 8 (Zone inputs)

These terminals are used for the 8 loop inputs zones 1 through 8 respectively. They will accept normally-closed or normally-open sensors.

Terminals 9-10 and 11 (Zone Outputs)

These are 3 identical, current limited, +12 VDC outputs, which are used to power one side of the normally-closed loops.

Terminal 12

This is a common negative (ground) output and is used for one side of the normally-open loops.

Terminals 13 through 20

These are the 3 zone light outputs which drive the remote module (s) zone annunciator lights. These outputs switch to common negative (ground) to turn on the lights.

Push-on Connector and Pigtail

The 2180 is supplied with a 36 inch pigtail, with connector, which connects between the 2180 and the control panel.

Pin 1/Black wire

This is the common negative (ground) input from the control panel power supply.

Pin 2/Red wire

This is the +12 VDC input from the control panel power supply.

Pin 3/Orange wire

This is the "ALARM" input from the control panel, which must switch to +12 VDC when the control panel is in alarm.

Pins 4 through 7 (Alarm Outputs)

These are the 4 alarm outputs which respond to the 8 zone inputs. These outputs are used to activate the alarm input (s) of the control panel, and switch to common negative (ground) when an associated input is violated.

They are arranged as follows:

Pin 4/Yellow wire - Controlled by Zones 1 & 2

Pin 5/Purple wire - Controlled by Zones 3 & 4

Pin 6/Gray wire - Controlled by Zones 5 & 6

Pin 7/Tan wire - Controlled by Zones 7 & 8

Pins 8-9-10 and 12

These are the 4 digital key inputs which parallel with the key inputs of the control. These inputs switch to +12 VDC as the digits are pressed at the remote key modules and do so in various combinations depending on which digits are pressed.

Pin 8 White	Pin 10 Brown
Pin 9 Green	Pin 12 Blue

The following is a table showing the voltages as they would appear on the inputs when the associated digits are pressed.

Digit Pressed	Pin 8/White	Pin 9/Green	Pin 10/Brown	Pin 12/Blue
No Digits	0	0	0	0
Digit 1	0	0	+12 VDC	0
Digit 2	0	+12VDC	0	0
Digit 3	0	+12VDC	+12 VDC	0
Digit 4	0	0	0	+12VDC
Digit 5	0	0	+12 VDC	+12VDC
Digit 6	0	+12VDC	0	+12VDC
Digit 7	0	+12VDC	+12 VDC	+12VDC
Digit 8	+12VDC	0	0	0
Digit 9	+12VDC	0	+12 VDC	0

NOTE: All voltages are measured to common negative (ground) terminal 12.

Pin 11/Pink wire

This is the "SYSTEM ARMED" input from the control panel. This input must switch to +12VDC when the control panel is armed.

OPERATION

Control Panel Not Armed

When the control panel is not armed the 8 zone lights and the 4 alarm outputs of the 2180 simply follow the status of the zone inputs.

If a zone input is violated the appropriate zone light will turn on and its associated alarm output will switch to common negative.

If a zone is shunted (by-passed) the zone light for that zone will be blinking on & off and the alarm output for that zone will now ignore that zone input.

Shunting a zone (s)

Zones can only be shunted (by-passed) when the control panel is not armed.

Shunting a Zone (s) Cont.

The procedure for zone shunting is as follows:

Step 1) Press digit 9 once.

Step 2) Press each digit corresponding to the zones which are to be shunted.

Step 3) Press digit 9 again

If the zone (s) has been successfully by-passed the associated zone light will be blinking on & off.

If a mistake is made while shunting, reset the 2180 by pressing the digit 3, three (3) times in succession and repeat the shunting procedure.

NOTE: Any zone can be shunted whether it is in a normal or violated condition.

Control Panel Armed

When the control panel is armed the zone lights and alarm outputs of the 2180 will function as follows:

The zone lights for those zones which are shunted (by-passed) will switch from blinking to ON steady. The alarm outputs of the 2180 will continue to ignore the zone inputs for the shunted zones.

If a zone input which is not shunted becomes violated, the zone light for that zone will begin blinking and its associated alarm output will switch to common negative (ground).

If the control panel is disarmed before it goes into alarm (as would happen if a normal entrance is made through a delayed door) the 2180 will reset and the blinking light will turn off when the control panel is disarmed.

However, if the control panel goes into alarm, the blinking zone (s) light will "Lock-in" and can only be turned off by first disarming the control panel and then resetting the 2180.

Resetting the 2180

The 2180 can only be Reset when the control panel is not armed. To Reset; press the digit 3 touch switch at the remote key module three (3) times in succession.

Zone Inputs

The 2180 is designed so that both normally-closed (N.C.) and/or normally-open (N.O.) sensors can be used with the system.

However, because of the necessity to limit the number of terminals on the 2180 to a reasonable level, the number of zones which can use normally-open loops is restricted to two (2).

If the system is using only normally-closed loops, the common side of these sensors can be connected to any one of the 3 zone outputs or split among the three as shown in Fig. 1:

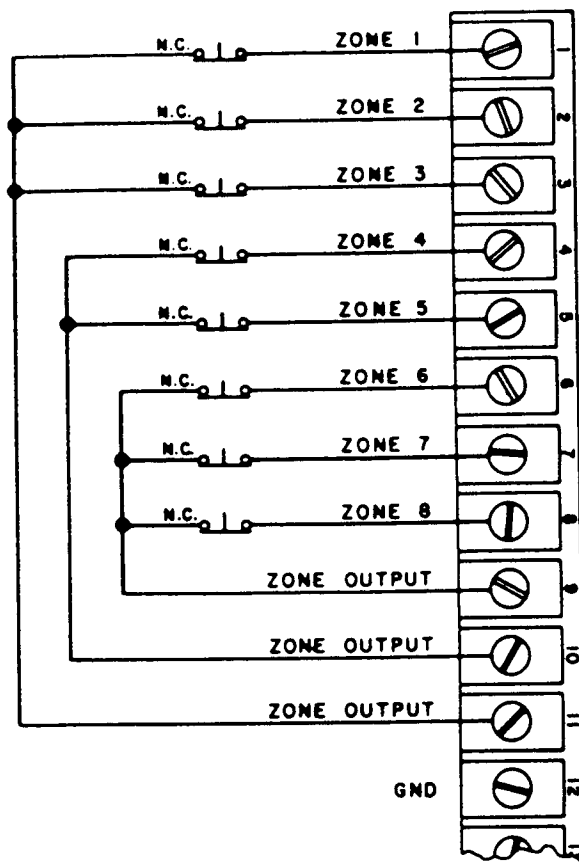

NOTE: For simplicity, figures 1 & 2 show only one N.C. and/or N.O. sensor for each zone. But, as with all Silent Knight systems multiple sensors can be connected in each zone loop.

If normally-closed and/or normally-open loops are used in the system, each zone which has a normally-open sensor must be connected by itself to one of the three (3) zone output terminals thus eliminating it for use with other zones: See figure 2.

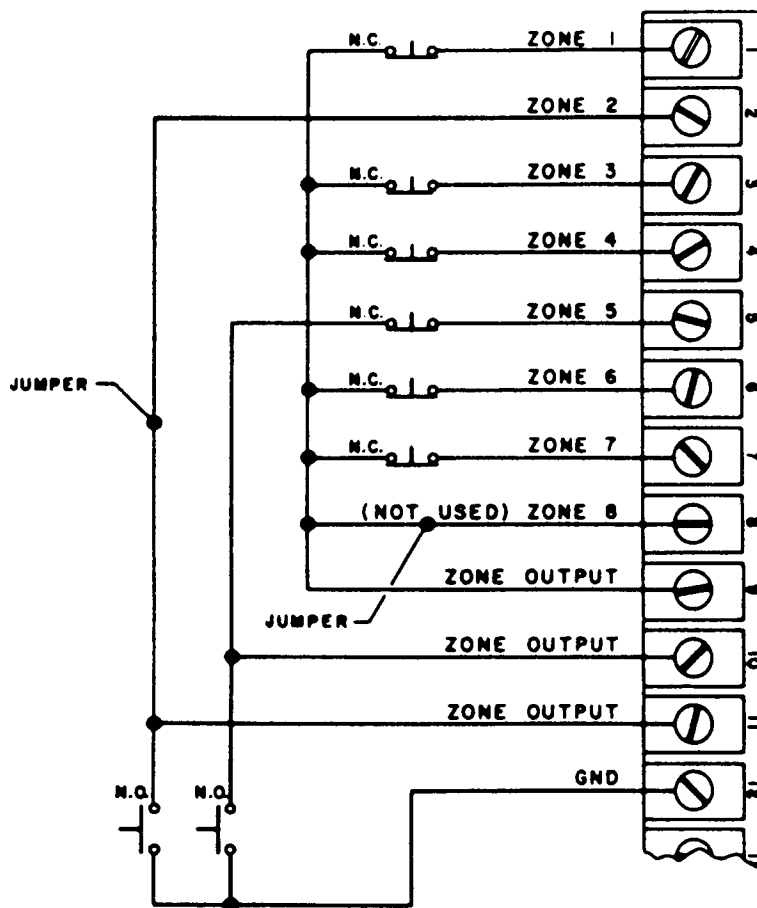

CAUTION: If a zone input is not used or if only normally-open (N.O.) sensors are used on a zone input, a jumper must be connected between that input and one of the zone outputs.

CONNECTIONS FOR 2120 or 2620

Figures 3, 4, and 5 are examples of the many different configurations in which the 2180 can be connected to the Models 2120 or 2620. There are other configurations which can be employed.

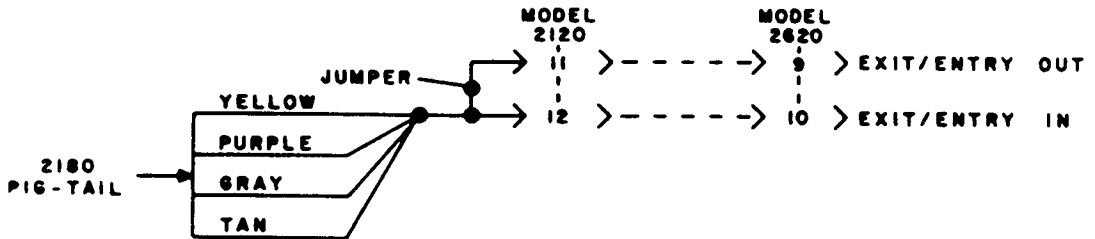
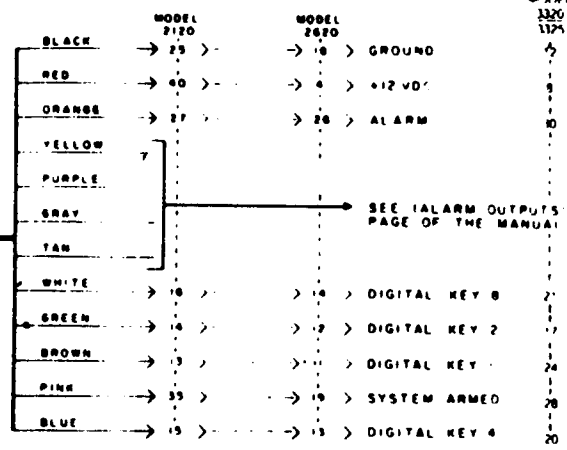

Figure 3

Figure 3
Shows all 8 zones connected to Exit/Entry loop of the control panel.

WKA
3320
1175



PIG TAIL

CAUTION PLUG IN CONNECTOR ONLY IN DIRECTION SHOWN

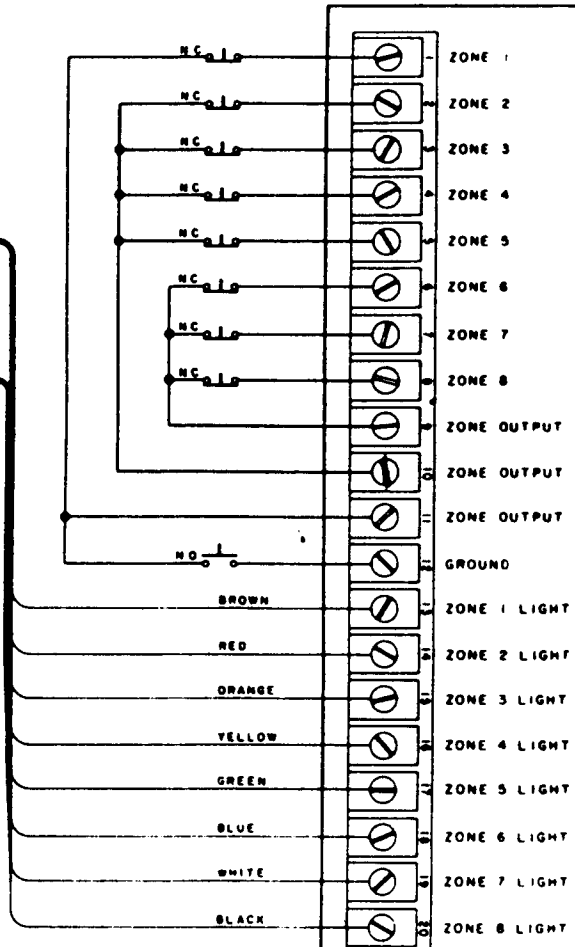
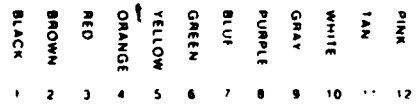
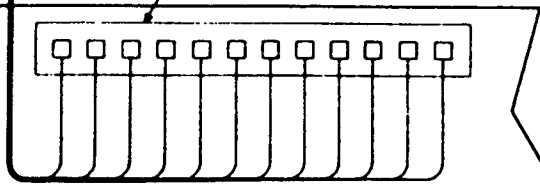

MODEL 2180

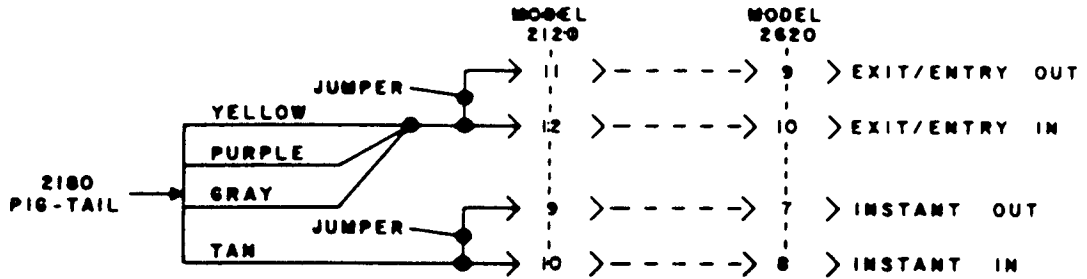

Figure 4

Figure 4

Shows zone 1-2-3-4-5 & 6 connected to the Exit/Entry loop and zones 7 & 8 connected to the Instant loop.

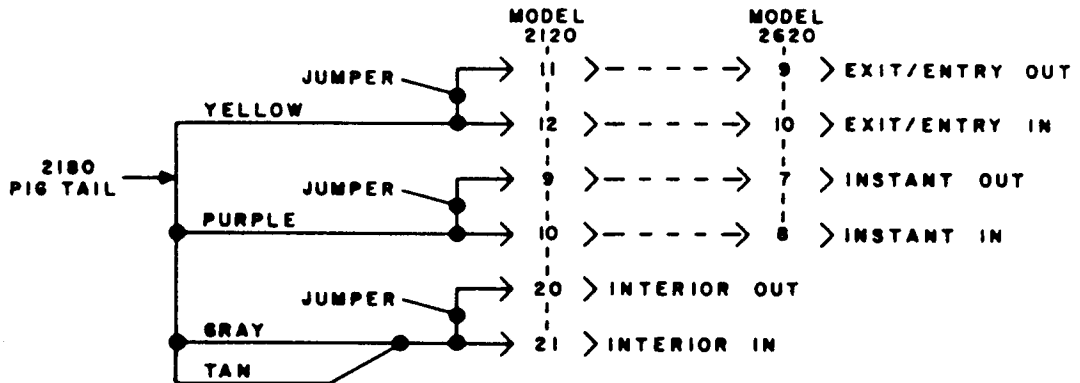

Figure 5

Figure 5

Shows zone 1 & 2 connected to the Exit/Entry loop, zones 3 & 4 connected to the Instant loop and zones 5-6-7 & 8 connected to the Interior loop (Model 2120 only).