

# R A D I O N I C S

## **READYKEY® K6000-AM Network Controller**

---

### **User's Guide**

## Notice

The material and instructions covered in this manual have been carefully checked for accuracy and are presumed to be reliable. However, Radionics, Inc. assumes no responsibility for inaccuracies and reserves the right to modify and revise this manual without notice.

It is our goal at Radionics, Inc. to always supply accurate and reliable documentation. If a discrepancy is found in this documentation, please mail a photocopy of the corrected material to:

Radionics, Inc.  
c/o Technical Writing Dept.  
1800 Abbott Street  
Salinas, CA 93901

## FCC Notice

This equipment generates and uses radio frequency energy. If not installed and used in accordance with the manufacturer's instructions, it may cause interference to radio and television reception. It has been tested and found to comply with the limits of restricted radiation devices which are used as field disturbance sensors pursuant to Subpart F of part 15 of FCC rules, which are designed to provide reasonable protection against radio communication interference. The operator of a field disturbance sensor, who is advised that his sensor is causing interference to an authorized radio service shall promptly stop operating the sensor, and operation shall not be resumed until the condition causing the harmful interference has been eliminated. The user, at his expense, will be required to take whatever measures may be required to correct the interference.

If necessary, the installer should consult an experienced radio/television technician for additional suggestions, or send for the "Interference Handbook" prepared by the Federal Communications Commission. This booklet is available from the U.S. Government Printing Office, Washington, D.C. 20402, stock # 004-000-00450-7.

FCC Registration Number: IDHM32Y6K2000

## Listing

UL 294—Access Control System Units

# Table of Contents

Section	Page
Introduction .....	5
Getting Started .....	5
Transaction Monitoring .....	6
Update .....	7
Doors and Alarm Status .....	8
Alarm Acceptance at K2000-AM or K2000-N .....	9
Manual Test .....	9
System Menus .....	11
The K6000-AM Editor .....	12
Keyboard Operation, Editor Structure & Screen Layout .....	12
Function Keys .....	12
The Main Menu .....	15
Personnel (Main Menu - 1) .....	16
Description of Personnel Fields .....	16
To Add New Personnel .....	17
To Void Personnel .....	17
Personnel Printout (F8) .....	18
Description of Personnel Printout Fields .....	18
Visitors (Main Menu - 2) .....	19
Description of Visitor Fields .....	19
To Add Visitor Keys .....	20
To Void Visitor Keys .....	20
Alarm Monitoring Menu (Main Menu - 3) .....	21
Alarm Messages (Alarm Menu - 1) .....	22
Description of Alarm Messages .....	22
Alarm Responses (Alarm Menu - 2) .....	23
Description of Alarm Monitoring Responses .....	23
Alarm Sensors (Alarm Menu - 3) .....	24
Description of Alarm Monitoring Sensors .....	24
Holiday Menu (Main Menu - 4) .....	25
Holiday Profiles (Holiday Menu - 2) .....	26
Description of Holiday Profiles .....	26
To Create Holiday Profiles .....	26
Holiday Periods (Holiday Menu - 1) .....	27
Description of Holiday Periods .....	27
To Create Holiday Periods .....	27
Doors & Access Menu (Main Menu - 5) .....	28
Time Periods (Doors & Access Menu - 5) .....	29
Description of Time Periods .....	29
Time Profiles (Doors & Access Menu - 4) .....	30
Description of Time Profiles .....	30
Access Points (Doors & Access Menu - 6) .....	31
Description of Access Points .....	31
Explanation of Door Lock Modes .....	32
Door Groups (Doors & Access Menu - 3) .....	34
Description of Door Groups .....	34
Access Levels (Doors & Access Menu - 2) .....	35
Descriptions of Access Levels .....	35
Access Codes (Doors & Access Menu - 1) .....	36
Description of Access Codes .....	36

## Table of Contents (cont'd.)

Section	Page
<b>Manual Lock/Unlock Doors (Doors &amp; Access Menu - 7)</b> .....	37
Description of Manual Lock/Unlock .....	37
<b>Event Analysis Menu (Main Menu - 6)</b> .....	38
<b>Historical Transactions (Event Analysis Menu - 1)</b> .....	39
Description of Historical Transactions Analysis .....	39
To Analyze the History .....	40
<b>Muster Mode (Event Analysis Menu - 2)</b> .....	40
To Select the Muster Mode .....	41
<b>Presence In Area (Event Analysis Menu - 3)</b> .....	42
Applications .....	42
<b>Void Personnel from Area (Event Analysis Menu - 4)</b> .....	43
Application .....	43
To Void Personnel from an Area .....	43
<b>Print Current User Report (Event Analysis Menu - 5)</b> .....	43
Programming for the New Report .....	44
Obtaining the Report .....	44
<b>Personnel Trace (Event Analysis Menu - 6)</b> .....	45
Description of Personnel Trace .....	45
<b>Editor Audit Trail (Event Analysis Menu - 7)</b> .....	46
Description of Audit Trail .....	46
To Analyze the Audit Trail .....	47
<b>System Configuration Menu (Main Menu - 7)</b> .....	48
<b>System Editor Data (Sys Config Menu - 1)</b> .....	49
<b>Door Control (Sys Config Menu - 2)</b> .....	51
Description of Door Control .....	51
<b>Download to all Door Controllers (Sys Config Menu - 3)</b> .....	53
<b>Synchronize System Clocks (Sys Config Menu - 4)</b> .....	54
<b>Poll Table (Sys Config Menu - 5)</b> .....	55
<b>Data Protection (Sys Config Menu - 6)</b> .....	56
Description of Data Protection .....	57
<b>Recording Control (Data Protection Menu - 1)</b> .....	57
Description of Recording Control .....	57
<b>Door Exclusion (Data Protection Menu - 2)</b> .....	58
Description of Door Exclusion .....	58
<b>Delete Transaction Data (Data Protection Menu - 3)</b> .....	59
Explanation of Delete Transaction Data .....	59
<b>Installation Configuration Utility (Sys Config Menu - 7)</b> .....	60
Description of Configuration Utility Menu .....	60
1 - PC Configuration .....	60
2 - Change Master Key .....	60
3 - Initialize Files .....	60
4 - Initialize Door Controller .....	61
5 - Initialize K2000-AM .....	61
<b>PC Configuration (Configuration Utility - 1)</b> .....	61
Description of PC Configuration .....	61
<b>Disk Functions Menu (Main Menu - 8)</b> .....	65
<b>Format A Diskette (Disk Functions Menu - 1)</b> .....	65
<b>Save System Database (Disk Functions Menu - 2)</b> .....	65
<b>Restore System Database (Disk Functions Menu - 3)</b> .....	65
<b>Archive Transaction Files (Disk Functions Menu - 4)</b> .....	66
<b>Backup Master Transaction File (Disk Functions Menu - 5)</b> .....	66
<b>Execute A DOS Command (Disk Functions Menu - 6)</b> .....	66

## Table of Contents (cont'd.)

Section	Page
Escape from K6000-AM System (Disk Functions Menu - 7).....	66
Transaction Types.....	67
Installation .....	70
Layout.....	70
The Interface Unit .....	71
The Line Driver Module .....	72
Software Installation .....	72
Modify your Files .....	73
Assign the Master Key .....	73
Start the K6000-AM .....	73
Check your System.....	74

## Introduction

The K2000-AM can be connected to a standard IBM Personal (or compatible) Computer using the K6000-AM. The K6000-AM enables complete programming and control of the K2000-AM System from a distance of up to 3,000 feet with the equipment provided. The minimum specifications required for the computer are:

- IBM PC/AT equivalent or PS2 Model 30/286 and above
- Minimum 10 Mb hard disk space
- 360 Kb 5.25" or 720 Kb 3.5" diskette drive
- CGA/EGA/VGA color monitor
- 640K memory (568K available)
- 1 RS232 serial port (COM 1, IRQ4, 3F8h-3FFh)
- 1 parallel printer port (LPT 1)
- MS DOS software V3.0 or higher, or IBM DOS

Using the K6000-AM provides the following features:

- Screen editing of all the K2000-AM controller data and K2000-N networked controllers on the PC.
- Desk top key and ID card administration using a compact key reader designed to fit alongside a standard PC keyboard.
- Connection from the PC reader to an under-desk interface and power supply unit. The interface unit provides connections to the PC serial port and a line driver output to the K2000-AM controller, thus only one serial port on the PC is required (COM 1 only). The interface can be connected with a DB9 or a DB25 PC serial cable to allow simple connection to a PC/AT or PS/2 computer.
- Up to a 3,000 foot connection between the PC interface and the K2000-AM controller using the built-in line driver and standard 22AWG 4-wire cable. A compact line driver is supplied to plug into the printer connection on the K2000-AM controller, which connects to the 4-wire cable.
- Independent data editing by the PC and PC key reader without connection to the K2000-AM controller. This allows preprogramming and subsequent downloading of databases.

Installation instructions are provided in the *Installation* section of this manual (beginning on page 70).

## Getting Started

This manual assumes that all the hardware has been installed and tested as necessary and that the K6000-AM software has been installed according to the *Installation* section.

The K6000-AM Editor enhances both the operation and user friendliness of the K2000-AM Area Master Door Controller. Once installed, the K6000-AM software provides full on-screen monitoring and editing facilities including transaction archive, search, and print. Also included is the ability to administer visitor keys on a short term basis. The K2000-AM keyboard is automatically disabled once the K6000-AM is connected. Key administration and the acceptance of alarms is then done at the K6000-AM using the PC Reader (provided with the K6000-AM).

## Transaction Monitoring Display

Radionics Inc. Readykey K6000-AM: Rev 1.2 v1.2 09:25:30 3/9/90  
K2000AM ON-LINE

POLLING - [2] [3] [4]

Date	Time	Door / Zone	ID	Name / Editor	Event
01/27	15:11			Master Editor	Editor On

When the K6000-AM Area Master Network Controller (K6000-AM Editor) program is operating, the user has the choice of two different monitoring displays - the Transaction Monitoring display and the Doors and Alarm Status display. Unless an Editor Key is used to gain access to the menus, these are the only two displays available.

**K2000AM** Followed by ON-LINE or OFF-LINE, indicating the K2000-AM's status with the K6000-AM.

**POLLING** [2], [3], or [4] indicate which K2000-N door controllers are communicating with the K6000-AM.

**Date and Time** The date and time the event occurred in the door controller. Alarms that occur while the K2000-AM is OFF-LINE can be manually acknowledged at the K2000-AM. When the K2000-AM is brought back ON-LINE, these alarms are reported with the time of occurrence to the K6000-AM. Sensor restorals are similarly reported. The local alarm acceptance (with editor identification) is reported to the K6000-AM, but acceptance must also be carried out at the K6000-AM.

Transactions can be routed by type and time to the screen (and highlighted) and/or printer. Those that are marked for a personnel trace are shown in a different color and are printed.

The K6000-AM is OFF-LINE with the K2000-AM when in the Configuration menu.

**Event**

A list of transactions, and their explanations can be found under *Transaction Types* at the end of the User's Guide (beginning on page 67).

Alarms from the Alarm Modules requiring acknowledgement appear at the bottom of the editor screens. To acknowledge the alarms, return to the Transaction Monitoring display. Only the first alarm is displayed at the bottom of the screen. Alarms are handled in the order in which they are received at the K6000-AM.

**Note:** Events only print while in the Transaction Monitoring Display. No events print while in the Door and Alarm Status Display or while in the Editor.

**Update**

A display along the bottom of the Transaction Monitoring Display and Door and Alarm Status Display will indicate the progress of any Download Update to the K2000-AM or K2000-N door controllers.



## Doors and Alarm Status Display

```

Radionics Inc. Readykey K6000-AM: Rev 1.2 v1.2 09:25:30 3/9/92
Door and Alarm Status for Door Controller: 1 - Last Updated: 0:00:00
Special Condition:
-----
Door          Door Name      Door Status      Override      Alarm
-----
1
2
3
4
-----
Alarm Zone Status
Zone State    Zone State    Zone State    Zone State
-----

```

Press S to change to the Doors and Alarm Status Display.

**Special Condition**      Override Alarm or Enclosure Tamper events reported here.

**Door Status**  
**State**                      This is Locked, Unlocked or Open (if door monitoring is enabled).

**Override**                      EMERGENCY, D/C OVERRIDE, Automatic, Manual Lock or Manual Unlock will be displayed here. (See page 67.)

**Alarm**                              Tamper/Forced or Left Open appear here.

**Alarm Zone Status**  
**State**                              Clear, Alarm, Iso, Manual Iso, Auto Iso appear here.

If an alarm occurs, the date, time, location and transaction are shown at the bottom of the screen. Return to the Transaction Monitoring display to view any text messages associated with the alarm, and to acknowledge alarms. You must return to the Transaction Monitoring display before entering the the Editor.

The bottom of the screen also shows the status of any updates that are in progress from the K6000-AM to the K2000-AM and connected door controllers.

Use the up and down cursor keys to change the display to other door controllers on line. Press ESC to change to the Transaction Monitoring Display.

## Alarm Acceptance at the K2000-AM or K2000-N

Editor keys may accept an alarm at the K2000-AM door controller. There are two types of alarms reported at the door controller display:

- Door Monitoring alarms
- Alarm Module Input Point alarms (when optional K2015 Alarm Module is installed)

The door controller display indicates the status of each channel in the following way:

*CH-*nn* D*

*nn* = The reader channel number 01 to 04.

*D* = Status of the Door Monitoring alarm.

Flashing *D* = Door alarm warning. An audible beep sounds. Acknowledgment with an editor key is required.

Steady *D* = Door alarm is still present although a key was presented to the door controller.

*D* not present = Door alarm is not present.

Status of the Alarm Module Input Point alarms are shown in the following way:

*12345678*

Flashing number = Alarm warning. A beep sounds. Acknowledgment with an editor key is required.

Steady number = The number appears steady on the presentation of a key.

Number not present = Number disappears when the cause of the alarm is cleared.

Presenting an editor key once to the front panel reader acknowledges all alarm conditions for the channel number displayed.

If alarms are reported on 3 channels, the editor key must be presented to the door controller reader 3 times. If the alarm input points are not restored each channel number will be displayed until the alarm input point is restored.

## Manual Test

UL 294 *Standard for Safety, Access Control Systems Units* requires that you manually test critical components (those whose malfunctioning will impair the operation of the product or will create the risk of fire or electric shock) periodically.

The manual test consists of testing the following components:

- Power supply
- Doors, readers, and monitoring points
- Network connection and event storage/retrieval

## Power Supply

1. Verify that AC power is supplied to each door controller by checking that the red AC indicator lamp is ON for each door controller.
2. Verify that the battery is properly connected by removing AC power from each door controller and verifying that the door controller continues to operate correctly.
3. Reconnect AC power to each door controller.

## Doors, Readers, and Monitoring Points

4. Verify the operation of each reader with an authorized Electronic Key. The operation of the locking mechanism and reader RED/GREEN, GREEN, or RED/YELLOW/GREEN LED will also be verified.
5. In systems where a request to exit is used, verify the operation of each RTE device. The operation of the locking mechanism will also be verified.
6. In systems where the reader operation provides an alarm signal bypass, test the operation of the alarm signal by opening the door (for example, from the inside) without an electronic key or request to exit and observing the alarm condition.
7. In systems where points (alarm modules) are monitored, test each point by activating the alarm point, without a bypass on the point, and observing the alarm condition.

## Network Connection and Event Storage/Retrieval

8. Events that occur at each door controller in a K2000-AM network will be transferred to the K2000-AM for storage and/or manual acknowledge. Verify that events occurring at K2000-N door controllers that are connected to the K2000-AM are passed to the K2000-AM. The door controller number should appear in the display of each K2000-N in the network. Each K2000-N should display the status of the individual channels.
9. Verify that database and editing changes made at the K2000-AM are communicated to each K2000-N. Add a key to the system with authority at each door controller. Verify this programming change by using the key at each reader on each controller.
10. After testing each reader on each controller, delete the key and verify that the key does not operate doors on each controller.

When you have completed these tests, ensure that the system has been returned to normal operation mode.



# System Menus

Editing features of the K6000-AM are 'menu driven', i.e., the user is requested to make one of a series of choices to carry out particular editing functions.

The following figure shows the relationship between the K6000-AM menus, and provides an illustration of the way in which all files and sub menus can be reached from the Main menu.

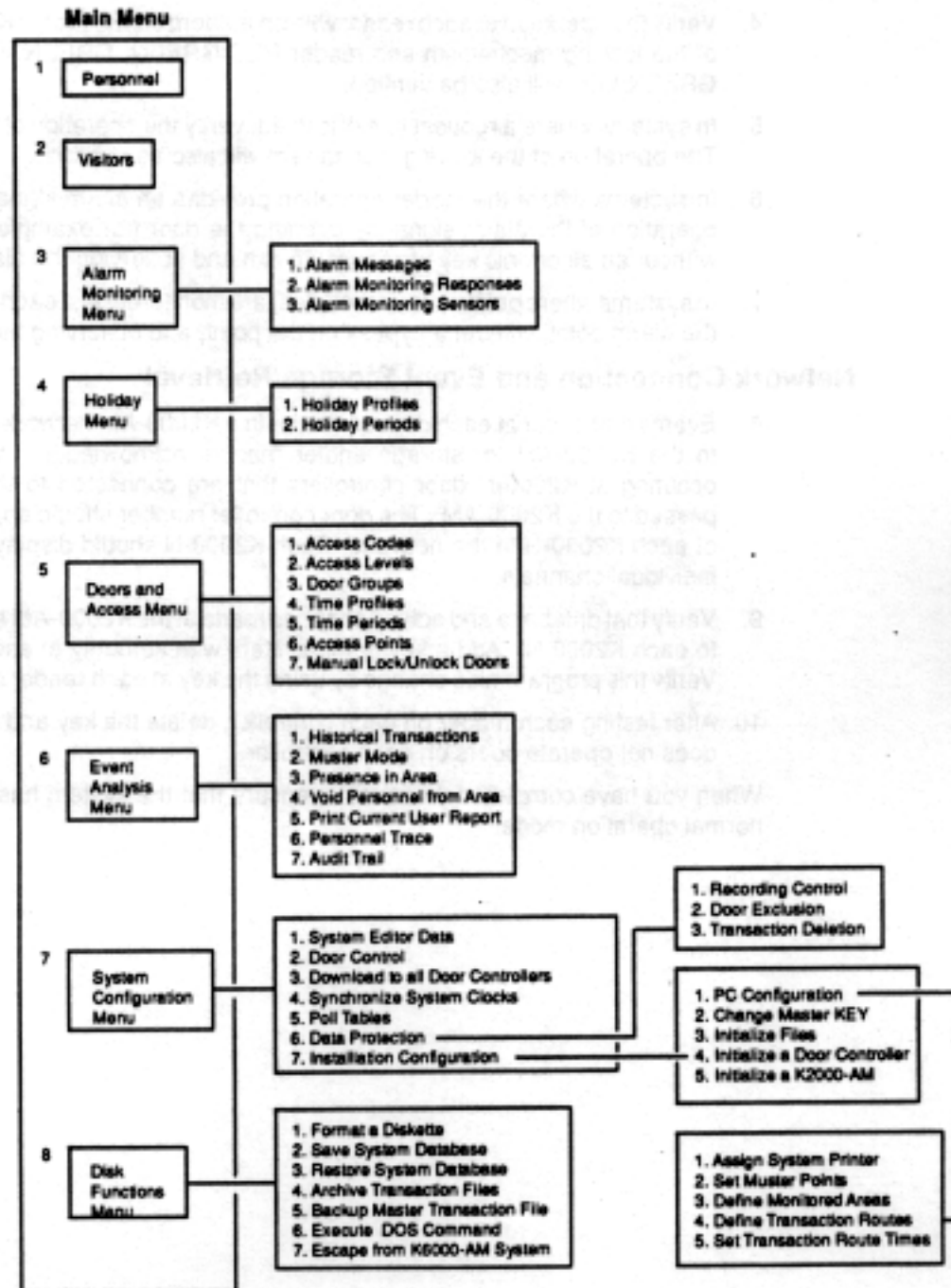

## The K6000-AM Editor

Enter the K6000-AM Editor by presenting an editor key to the PC Reader. If the key is valid, the display will prompt for a password. Enter the password (maximum of 8 characters) then press RETURN or ENTER. If you make a mistake, the PC will beep. If this happens, press ESC and repeat the above sequence. There is a built in delay of five seconds between repetitive reads of the same key. Do not hold your key up to the PC reader for longer than a few seconds.

Once successfully logged into the Editor, you will be presented with the Main menu displaying eight options. If the keyboard is not used for a period of a few minutes, the Editor will exit back to the normal monitoring mode (except while in the Installation Configuration menus).

Remember that not all options may be available to all editor keys (see *System Editor Data*). If an editor key has been restricted to accept alarms only, it will not be able to gain entry to the K6000-AM Editor.

## Keyboard Operation, Editor Structure and Screen Layout

Entry into menus and files is by the keyboard from the main or sub menus. The ESC key is used as a convenient means of exit. It causes the system to terminate the current editing task and return to the next level up in the command structure. All invalid key strokes are ignored, and an audible beep is issued in response to some of these.

All relevant key functions are detailed in this chapter. As data is changed in the database, it is highlighted in red. This signifies that it is *not yet confirmed*. To confirm entry, press ENTER. If ENTER is not pressed, the field will retain its original contents.

## Function Keys

ENTER	Confirms function or data entry into field. On entry, data turns from red to white.
DELETE	Depending on where the cursor is located, it moves to the end or beginning of a field. Deletes the character the cursor is located under.
BACKSPACE	Deletes the character before the cursor and highlights other characters.
→	Moves cursor right one character. If cursor is under the last character of a field, it moves to under the first character.
←	Moves cursor left one character. If cursor is under first character of a field, it moves it to under the last character.
↑	Moves cursor up one field. If cursor is on first field, it now selects the last field. This causes update of file information.
↓	Moves cursor down one field. If cursor is on last field, it now selects the last field. This causes update of file information.
PAGE UP	Moves display back one screen.

## Function Keys (cont'd.)

<b>PAGE DOWN</b>	Moves display forward one screen.
<b>TAB</b>	Moves cursor to the next field. If the cursor is on the last field, it moves to the first field.
<b>SHIFT/TAB</b>	Moves cursor to the previous field. If the cursor is on the first field it moves to the last field.
<b>HOME</b>	Selects first line of the data entry screen.
<b>ESC</b>	Ends current task.
<b>F1</b>	Brings up the <b>HELP</b> screen for the particular display. At the Menu level it explains the editing options. At the programming level it explains how to use the data entry keys. <b>HELP</b> screens are cleared by pressing <b>ESC</b> .
<b>F2</b>	Selects a specific record for editing. When editing personnel, visitor or operator records, entering a name will alphabetize the records, and select the record with the nearest match to the entered name. Entering a number will numerically list the records, and select the record of the number entered. A <b>Record Selection</b> prompt appears at the bottom of the screen. Enter your selection here. Then press <b>ENTER</b> .
<b>SHIFT/F2</b>	Marks a keyholder for Personnel Trace (an asterisk appears next to the user's name). <b>Do not use SHIFT/F2 in any other screen.</b>
<b>ALT/F2</b>	Selects the first available blank name field. This only functions on personnel, visitor or operator data records.
<b>F5</b>	Copies the current field contents into the template. Used with <b>F6</b> for block copying fields. <b>Do not use with multi-line records.</b>
<b>ALT/F5</b>	Copies the selected field of the record to the template. <b>Do not use with multi-line records.</b>
<b>SHIFT/F5</b>	Clears the selected field (at the cursor) from the template.
<b>F6</b>	Copies the current template contents of the field you are in to the field. Will not copy name fields into personnel, visitor, or operator records. <b>Do not use with multi-line records.</b>
<b>SHIFT/F6</b>	Clears field at the position of the cursor. Will not work on name fields in personnel, visitor or operator screens.
<b>ALT/F6</b>	Copies the current template contents to all fields in the record. Will not copy name fields in personnel, visitor or operator fields. <b>Do not use with multi-line records.</b>

## Function Keys (cont'd.)

**F8** Prints a specified number of records from the selected file starting with the current record. Note that when printing personnel, visitor, or operator records, only those records with assigned names are printed. The system will search for the specified number of valid records and will display the number of records it is searching for. Printing always terminates at the last record in the file.

**Note:** F8 is not used on history analysis records. Press **ESC** at any time to stop printing.

**F9** Add keys. Functions only on personnel, visitor and editor records. Adds the key(s) presented to the current record. Only functions if a name has been previously assigned to the record, and it has no key. Press **ESC** to end the function.

**ALT/F9** An automatically repeating version of **F9**. Terminates when no records with names or keys remain, or when **ESC** is pressed.

**F10** Voids personnel, visitor or operator records. Voids the current record as long as it has an assigned name. Requires Yes/No confirmation before void is executed.

**TEMPLATE** Allows an area of data to be duplicated through different records. To transfer data from the records to the template, place the cursor at the desired information and press **F5**. This information appears in the template. To transfer data from the template into the record field, place the cursor where you want the information to appear and press **F6**. The information is placed in the record field.

**Note:** During editing, any changes performed at the K6000-AM are only sent to the K2000-AM and K2000-N Door Controllers when the cursor is moved to another record, or editing is ended using **ESC**.

All transaction report printing and alarm acknowledgments are suspended during editing and resume on exit from the main menu.

## The Main Menu

Radionics Inc. Readykey K6000-AM: Rev 1.2 v1.2 09:25:30 3/9/92

### MAIN MENU

- |                      |                          |
|----------------------|--------------------------|
| 1 - Personnel        | 5 - Doors and Access     |
| 2 - Visitors         | 6 - Event Analysis       |
| 3 - Alarm Monitoring | 7 - System Configuration |
| 4 - Holidays         | 8 - Disk Functions       |

Selection:

The main menu is the 'gateway' to the editing functions available to the user. The screen presents a range of options available to the user. These are selected by choosing a number 1 to 8.

Any information entered by the user into the databases requires pressing **ENTER**. When information is accepted, the characters change from red to white. The **TAB** key enables the user to move between fields in a record. A constant reminder of the function keys (F1 to F10) is available along the bottom of the screen. If a function key (e.g., F2 - **SELECT**) is pressed when the function is not available on that screen, a beep will sound.



## Personnel (Main Menu - 1)

Radionics Inc. Readykey K6000-AM: Rev 1.2 v1.2 10:35:20 12/20/92

### Personnel

Personnel	Name	Holiday Profile	Access Code	PIN
3996		00	000	0000
3997		00	000	0000
3998		00	000	0000
3999		00	000	0000
4000		00	000	0000
1	SHEAMUS HEANEY	T 00	000	9311
2	WILLIAM YEATS	T* 00	000	7700
3	OCTAVIO PAZ	T* 00	000	8859
4	AMY LOWELL	T 00	000	0670
5	HUGH MEREDITH	T 00	000	0571

- Template

| F1 = | F2 = | F3 = | F4 = | F5 = | F6 = | F7 = | F8 = | F9 = | F10 =  
| help | select | | | >temp | temp> | | print | add | void

The personnel file holds information relating to all keyholders present in the system.

### Description of Personnel Fields

- Personnel** The ID number used to refer to this keyholder. Personnel can be assigned IDs in any order. Keyholders will be displayed in either numeric or name order depending on the previous F2 select command.
- Name** A 20-character keyholder name. The name can not begin with numbers or spaces. It must be entered in capital letters. It must be unique.
- Holiday Profile** The Holiday Profile (1-24 or 0) assigned to this keyholder. A zero entry disables the holiday feature for that keyholder. A valid Holiday Profile prevents access by a person for the time the profile is active.
- Access Code** The Access Code (1-128 or 0) assigned to the keyholder. A zero entry locks out all door access for the key assigned to this keyholder.
- PIN** A four digit Personal Identification Number derived from the assigned key code. Only displayed and printed if the editor has the acceptable editor level. This number cannot be changed.

A "T" against a keyholder's name signifies a key is assigned to that record.

An "\*" indicates that a personnel trace is active for the user (activated by pressing SHIFT/F2).

## To Add New Personnel

1. Use the cursor keys or **ALT/F2** to select the next free line.
2. Check all fields are clear. Use **SHFT/F6** on any which are not blank.
3. Type in the keyholder name in the Name field, then press **ENTER**.
4. If there is more than one keyholder to add, repeat 1, 2 and 3 for each as required.
5. With the cursor still on the Name field, press **F9** to add a key for the user.
6. If you have more than one key to add, use **ALT/F9** to add in blocks.
7. Present keys to the PC reader, or type in key codes until required records are added. Adding may be terminated using the **ESC** key.
8. Assign a Holiday Profile and an Access Code for each user as required.

**Remember:** If a number of keys have identical data, the most efficient way to add them is to use the template. The template allows an area of data to be duplicated through different records. Place the cursor at the desired information and press **F5**. The information will appear in the template. Move the cursor to the desired records and press **F6**. whatever is in the template appears in the field at the position of the cursor, and is automatically entered. **SHFT/F5** clears the template.

**Note:** The template does not function in keyholder name fields.

## To Void Personnel

1. Move the cursor to the keyholder name field.
2. Press **F10**.
3. Press **Y** to void the record; **N** or **ESC** to abort the void command.

**Note:** Historical information is recorded by keyholder number, not name. Use caution in re-issuing keyholder numbers immediately to new users, because historical data will reference the new user name. For clarity of historical information, enter a description in the name field of voided personnel, indicating the prior name and date voided. Use an Access Code of 000 for these entries.

## Personnel Printout (F8)

Radionics Inc. Readykey K6000-AM: Rev 1.2 v1.2 09:25:30 3/9/92

### K6000-AM DATABASE PRINTOUT

#### Personnel

Printed order: 1) Alphabetical  
2) Numerical  
3) KEY Code

Filter type: 4) None  
5) Access code  
6) Door Group  
7) Time Period

8) START:0001 9) RANGE: 4000

| F1 - | F2 - | F3 - | F4 - | F5 - | F6 - | F7 - | F8 - | F9 - | F10 -  
| help | | | | | | | print | |

The Personnel Printout defaults to numerical order with no filter selected. The START section contains the number of the record the cursor is presently on and the RANGE section defaults to the maximum number of records in the file. To print out the personnel file, press F8 when you are in the personnel file display.

### Description of Personnel Printout Fields

#### Printed Order (1,2,3)

Displays the order in which the keyholders print. The order currently selected is highlighted. Enter 1,2 or 3 to select the printout order. The Key Code (FFFFFFFF if none is entered) is included with the printed report.

#### Filter Type (4,5,6,7)

Displays how the keyholders to be printed filter out, i.e. by Access Code, Door Group or Time Period. The currently selected mode is displayed in a different color. Enter 4,5,6 or 7 to select the filter. If no filter is required then select 4 and all records within the range will be printed.

#### Matching

This entry will appear if a filter is selected. An entry here indicates a value for the particular type of filter to be matched.

#### START and RANGE (8,9)

Defines which range of keyholders print. Selecting 8 allows the user to specify where keyholder printing starts. Selecting 9 allows the user to define the maximum number of keyholders to be printed.

## Visitors (Main Menu - 2)

Radionics Inc. Readykey K6000-AM: Rev 1.2 v1.2 09:25:30 3/9/92

### Visitors

Visitor	Name	Access Code	Dates		PIN
			From	To	
746		000	00/00/00	00/00/00	0000
747		000	00/00/00	00/00/00	0000
748		000	00/00/00	00/00/00	0000
749		000	00/00/00	00/00/00	0000
750		000	00/00/00	00/00/00	0000
1	T.E. Lawrence	T 000	00/00/00	00/00/00	2731
2	E.M. Forster	T 000	00/00/00	00/00/00	6256
3		000	00/00/00	00/00/00	0000
4		000	00/00/00	00/00/00	0000
5		000	00/00/00	00/00/00	0000

- Template

| F1 = | F2 = | F3 = | F4 = | F5 = | F6 = | F7 = | F8 = | F9 = | F10 =  
| help | select | | | | >temp | temp> | | print | add | void

The visitor file allows temporary access over a specified length of time. It is available with the K6000-AM, but not with the stand-alone K2000-AM when editing is done at the front panel.

### Description of Visitor Fields

<b>Visitor</b>	The ID number used to refer to this keyholder. Visitors can be assigned IDs in any order. Keyholders will be displayed in either numeric or name order, depending on the previous F2 SELECT command.
<b>Name</b>	A 20 character name. The name can not begin with numbers or spaces. The name must be unique.
<b>Access Code</b>	As in the personnel file, Access Level relates to entry to specified areas.
<b>Dates From</b>	A calendar date e.g., 09/25/90 to indicate the date a key can be used from. A date of 01/01/00 or 00/00/00 indicates an empty date field.
<b>Dates To</b>	A calendar date e.g., 09/26/90 to indicate the date a key can be used until. The key will be automatically invalidated after this date.
<b>PIN</b>	Four digit Personal Identification Number of the visitor derived from the assigned key code.

## To Add Visitor Keys

1. Use the cursor keys or **ALT/F2** to select a free line.
2. If fields are not clear, either **SPACE** over them or use **SHIFT/F6**.
3. Type in the keyholder name in the name field.
4. With the cursor still in the name field, press **F9**. Present the key to the PC Reader or type in the code. A "T" signifies that the key has been added.
5. Use the **TAB** key to move across the record to other fields. Type in the Access Code, then press **ENTER**.

The key added becomes valid from, and including, the first date entered. It remains valid until the end of the second date. The access code dictates where and when the keyholder can gain access to a given point.

## To Void Visitor Keys

1. Move the cursor to the visitors name field.
2. Press **F10**.
3. Press **Y** to void the record; **N** or **ESC** to abort the void command.

## Alarm Monitoring Menu (Main Menu - 3)

Radionics Inc. Readykey K6000-AM: Rev 1.2 v1.2 09:25:30 3/9/92

### A L A R M M O N I T O R I N G M E N U

- 1 - Alarm Messages
- 2 - Alarm Responses
- 3 - Alarm Sensors

Selection:

The K2000-AM and each K2000-N Door Controller can monitor up to 8 alarm zones on each reader channel if a K2015 Alarm Module is installed. Each door controller may have up to 32 (4 x 8) alarm sensor inputs. Each alarm module is equipped with four programmable relay outputs for alarm bells or alarm communicators.

When a possible alarm event occurs, the system checks that:

1. The alarm occurs during a time that the alarm is armed; i.e., not isolated.
2. There is no manual override applied by an operator to the alarm input.

Once an alarm condition has been established, the Alarm Sensors file describes which Alarm response the door controller and K6000-AM will give. The Alarm Responses file references the Alarm Messages file to determine what should be displayed on the screen to alert the operator of the alarm condition.

The Alarm Responses Engage/Isolate (enable/disable) the Alarm Sensor inputs assigned to the Alarm Response. This is done either manually or by Time Profile control.

## Alarm Messages (Alarm Menu - 1)

Radionics Inc. Readykey K6000-AM: Rev 1.2 v1.2 09:25:30 3/9/92

### Alarm Messages

Alarm Message	Display Text
508	
509	
510	
511	
512	
1	MAIN VEHICLE GATE
2	CALL (408) 555-7304
3	DELIVERY YARD
4	PLANT MANAGER
5	

- Template

| F1 - | F2 - | F3 - | F4 - | F5 - | F6 - | F7 - | F8 - | F9 - | F10 -  
| help | select | | | | >temp | temp> | | print | |

### Description of Alarm Messages

In order to provide centralized identification of the alarm conditions, a file containing programmable messages is provided. This consists of 512 messages, each consisting of up to 32 characters. Up to 4 of these messages can be automatically displayed upon activation of an alarm.

Thus, an alarm message example could read similar to:

MAIN VEHICLE GATE	CALL (408) 555-7304
DELIVERY YARD	PLANT MANAGER

## Alarm Responses (Alarm Menu - 2)

Radionics Inc. Readykey K6000-AM: Rev 1.2 v1.2 09:25:30 3/9/92

### Alarm Responses

Alarm Response	Alarm Messages				TP	ON/ OFF
	1	2	3	4		
124	0000	0000	0000	0000	00	OFF
125	0000	0000	0000	0000	00	OFF
126	0000	0000	0000	0000	00	OFF
127	0000	0000	0000	0000	00	OFF
128	0000	0000	0000	0000	00	OFF
1	0001	0002	0003	0004	00	ON
2	0000	0000	0000	0000	00	OFF
3	0000	0000	0000	0000	00	OFF
4	0000	0000	0000	0000	00	OFF
5	0000	0000	0000	0000	00	OFF

- Template

| F1 = | F2 = | F3 = | F4 = | F5 = | F6 = | F7 = | F8 = | F9 = | F10 =  
| help | select | | | | >temp | temp> | | print. | |

### Description of Alarm Responses

- Alarm Response** One of 128 potential responses to assign to an Alarm Input Sensor. The Alarm Sensors file uses these responses for each alarm input on each alarm module.
- Alarm Messages** Four alarm messages to display in response to the Alarm Input Sensor. The numbers programmed under alarm messages 1-4 are derived from the Alarm Messages file, containing, for example, instructions to be followed and the area of an alarm.
- TP** Automatically isolates the Alarm Inputs that the response is assigned to while the specified Time Profile is active. A TP of 00 is engaged 24 hours a day, every day.
- ON/OFF** An on/off switch to manually engage (ON) or isolate (OFF) the Alarm Sensors that this response is assigned to. (Toggle with SPACE bar.)



## Alarm Sensors (Alarm Menu - 3)

Radionics Inc. Readykey K6000-AM: Rev 1.2 v1.2 09:25:30 3/9/92

### Alarm Sensors

Alarm Sensors	1	2	3	4	5	6	7	8
16	000	000	000	000	000	000	000	000
	0000	0000	0000	0000	0000	0000	0000	0000
	0000	0000	0000	0000	0000	0000	0000	0000
1	001	000	000	000	000	000	000	000
	0000	0000	0000	0000	0000	0000	0000	0000
	0000	0000	0000	0000	0000	0000	0000	0000
2	000	000	000	000	000	000	000	000
	0000	0000	0000	0000	0000	0000	0000	0000
	0000	0000	0000	0000	0000	0000	0000	0000

- Template

| F1 = | F2 = | F3 = | F4 = | F5 = | F6 = | F7 = | F8 = | F9 = | F10 =  
| help | select | | | | >temp | temp> | | print | |

## Description of Alarm Sensors

### Alarm Sensors 1 - 16

Each represents one alarm module channel (1 to 4 are assigned to door controller 1; 5 to 8 to door controller 2; 9 to 12 to door controller 3; and 13 to 16 to door controller 4). One channel covers the eight inputs which can be monitored by 1 alarm module.

A column consists of 3 rows. The first row for each channel refers to an Alarm Response Number. Each alarm input may generate 1 to 4 printable alarm messages, and this first row refers to the alarm response record detailing the messages for a response for each individual input.

The second row consists of groups of 4 digits each representing a momentary (0.5 second minimum) alarm module relay state, "-" for OFF, 1-4 for ON (enter 1, 2, 3 or 4 to toggle between "-" and the number). Therefore, if relay 3 is required to respond momentarily to an alarm on input 1 then "- 3 -" will be programmed in row 2 of Channel 1.

The third row (latched response) is not used in the K6000-AM system.

## Holiday Menu (Main Menu - 4)

Radionics Inc. Readykey K6000-AM: Rev 1.2 v1.2 09:25:30 3/9/92

### HOLIDAY MENU

1 - Holiday Profiles

2 - Holiday Periods

Selection:

The K6000-AM takes account of national and domestic holidays and renders a user's key or Time Period invalid. The Holiday Period file consists of 254 Holiday Periods, each with the start dates of holidays and the days duration of that holiday. The Holiday Period file is referenced by the Holiday Profile file. Up to 24 Holiday Profiles, each referencing up to 20 Holiday Periods, can be defined.

## Holiday Periods (Holiday Menu - 2)

Radionics Inc. Readykey K6000-AM: Rev 1.2 v1.2 09:25:30 3/9/92

### Holiday Periods

Holiday Period	Period Start	Dura- tion Days
250	00/00/00	01
251	00/00/00	01
252	00/00/00	01
253	00/00/00	01
254	00/00/00	01
1	00/00/00	01
2	05/03/90	01
3	00/00/00	01
4	00/00/00	01
5	00/00/00	01

- Template

| F1 = | F2 = | F3 = | F4 = | F5 = | F6 = | F7 = | F8 = | F9 = | F10 =  
| help | select | | | | >temp | temp> | | print | |

### Description of Holiday Periods

- Period** The period number (1 - 254).
- Period Start** Calendar date indicating the start of a holiday period. A date of 01/01/00 or 00/00/00 indicates an empty date field.
- Duration Days** The number of days over which a holiday period is effective (1-32).

### To Create Holiday Periods

1. Move to Holiday Period number 1. Enter the date (e.g., 07 14 90). Press ENTER.
2. Press TAB to move to the duration field.
3. Type in number of days for Holiday Period (e.g., 14). Press ENTER.
4. It is recommended to get a print out (press F8) of these for quick reference when editing the Holiday Profile file.

## Holiday Profiles (Holiday Menu - 1)

Radionics Inc. Readykey K6000-AM: Rev 1.2 v1.2 09:25:30 3/9/92

### Holiday Profiles

Holiday Profile	ON/OFF	Holiday Periods									
23	OFF	000	000	000	000	000	000	000	000	000	000
		000	000	000	000	000	000	000	000	000	000
24	OFF	000	000	000	000	000	000	000	000	000	000
		000	000	000	000	000	000	000	000	000	000
1	ON	000	000	000	000	000	000	000	000	000	000
		000	000	000	000	000	000	000	000	000	000
2	OFF	000	000	000	000	000	000	000	000	000	000
		000	000	000	000	000	000	000	000	000	000
3	OFF	000	000	000	000	000	000	000	000	000	000
		000	000	000	000	000	000	000	000	000	000

- Template

| F1 - | F2 - | F3 - | F4 - | F5 - | F6 - | F7 - | F8 - | F9 - | F10 -  
| help | select | | | | >temp | temp> | | print | |

### Description of Holiday Profiles

**Profile** The profile number (1 - 24). Holiday Profile number 1 is automatically assigned to the holiday control of Time Periods assigned to Access Codes, Doors, Alarm Responses and Transaction Routing. Holiday Profiles (1 - 24) are also assigned to each user to provide vacation schedules.

**Holiday Periods** Up to 20 of the Holiday Periods (1 - 254 or 0) previously assigned.

### To Create Holiday Profiles

1. Move to Profile number. Set ON/OFF to ON with the **SPACE** bar. Press **ENTER**.
2. Press **TAB** to move to the first Holiday Period Enter a Holiday Period number (001 - 254). Press **ENTER**.
3. Press **TAB** to move to the next Holiday Period field.
4. The tab key will take you through all 20 record fields. To move backwards press **SHIFT** and **TAB** together.
5. Press **ESC** to exit the Holiday Profile file.

## Doors & Access Menu (Main Menu - 5)

Radionics Inc. Readykey K6000-AM: Rev 1.2 v1.2 09:25:30 3/9/92

### DOORS & ACCESS MENU

- |                   |                              |
|-------------------|------------------------------|
| 1 - Access Codes  | 5 - Time Periods             |
| 2 - Access Levels | 6 - Access Points            |
| 3 - Door Groups   | 7 - Manual Lock/Unlock Doors |
| 4 - Time Profiles |                              |

Selection:

The Doors & Access Menu refers to all aspects of the system which relate to a particular location (Access Points, Door Groups and Access Levels), or a given time (Time Periods and Time Profiles) in the system.

Time Profiles, Door Groups and Access Levels form an Access Code. This Access Code is then assigned to the Personnel or Visitor file. This means that where and when a key is valid is established in this section. The Doors & Access Menu consists of seven options. This screen includes Manual Lock/Unlock of doors.

The logical order to program these items (the order presented in this manual) is:

- 1) Time Periods
- 2) Time Profiles
- 3) Access Points
- 4) Door Groups
- 5) Access Levels
- 6) Access Codes

## Time Periods (Doors & Access Menu - 5)

Application of time to an access control system is used for a variety of reasons:

- To define when a person is allowed access through a particular door.
- To unlock a door e.g., a reception door, between 9:00 a.m and 5:00 p.m.
- To prevent a door from unlocking during a preset holiday period (see *Holiday Profiles*).
- To isolate alarm sensors during working hours and then re-enable them outside working hours.
- To define transaction routing to the display screen and printer.

Radionics Inc. Readykey K6000-AM: Rev 1.2 v1.2 09:25:30 3/9/92

### Time Periods

Time Period	Period Start	Period End	Valid Days
			M T W T F S S H
28	00:00	00:00	- - - - -
29	00:00	00:00	- - - - -
30	00:00	00:00	- - - - -
31	00:00	00:00	- - - - -
32	00:00	00:00	- - - - -
1	00:00	00:00	- - - - -
2	00:00	00:00	- - - - -
3	00:00	00:00	- - - - -
4	00:00	00:00	- - - - -
5	00:00	00:00	- - - - -

- Template

| F1 - | F2 - | F3 - | F4 - | F5 - | F6 - | F7 - | F8 - | F9 - | F10 -  
| help | select | | | | >temp | temp> | | print | |

### Description of Time Periods

**Time Period** 1 - 32 Time Periods. Up to 3 Time Periods are assigned to each Time Profile.

**Period Start** Start time of the period.

**Period End** End time of the period. Time Periods should not cross midnight.

**Valid Days** Select days Monday (1) through Sunday (7) and Holiday (8). When selected, Holiday (H) will prevent the Time Profiles from activating when Holiday Profile 1 is active.

## Time Profiles (Doors & Access Menu - 4)

Radionics Inc. Readykey K6000-AM: Rev 1.2 v1.2 09:25:30 3/9/92

### Time Profiles

Time Profile	ON/OFF	Time Period 1	Time Period 2	Time Period 3
28	OFF	00	00	00
29	OFF	00	00	00
30	OFF	00	00	00
31	OFF	00	00	00
32	OFF	00	00	00
1	ON	00	00	00
2	ON	00	00	00
3	OFF	00	00	00
4	OFF	00	00	00
5	OFF	00	00	00

- Template

| F1 - | F2 - | F3 - | F4 - | F5 - | F6 - | F7 - | F8 - | F9 - | F10 -  
 | help | select | | | | >temp | temp> | | print | |

### Description of Time Profiles

**Time Profile** 1 - 32. Each Time Profile is made of 1, 2 or 3 Time Periods linked together. A printout of Time Periods makes this easier.

**ON/OFF** ON enables the Time Profile; OFF disables the Time Profile. (Toggle with SPACE bar.) A Time Profile that is OFF is active 24 hours, 7 days (e.g., there is no schedule for the Time Profile). A Time Profile that is ON, yet has no Time Periods, is also active 24 hours, 7 days.

**Time Period 1** The first Time Period in the Time Profile.

**Time Period 2** The second Time Period in the Time Profile.

**Time Period 3** The third Time Period in the Time Profile.

## Access Points (Doors & Access Menu - 6)

Radionics Inc. Readykey K6000-AM: Rev 1.2 vl.2 09:25:30 3/9/92

### Access Points

Access Point	Name	LRT	DOT	TP	Lock Mode
12		000	000	00	- - - - -
13		000	000	00	- - - - -
14		000	000	00	- - - - -
15		000	000	00	- - - - -
16		000	000	00	- - - - -
1	UNUSED	000	000	00	- - - - -
2	UNUSED	000	000	00	- - - - -
3	BOILER ROOM	002	000	00	- - - - -
4	FRONT DOOR TO LOBBY	002	005	00	- - - - -
5		000	000	00	- - - - -

- Template

| F1 = | F2 = | F3 = | F4 = | F5 = | F6 = | F7 = | F8 = | F9 = | F10 =  
 | help | select | | | | >temp | temp> | | print | |

This file consists of 16 Access Points, four for each door controller.

### Description of Access Points

- Access Point** Each represents one reader channel. Channels 1 to 4 are assigned to door controller 1; channels 5 to 8 are assigned to door controller 2; channels 9 to 12 are assigned to door controller 3; and channels 13 to 16 are assigned to door controller 4.
- Name** The door is given a name of up to 20 characters for identification purposes.
- LRT** Lock Release Time is the time in seconds that the electric lock is unlocked allowing entry / exit (0 - 255 seconds).
- DOT** Door Open Time is the time in seconds that the door may be held open. After this set time an alarm may be activated and a door left open alarm created (0 - 255 seconds). For reader wiring tamper monitoring, always program door open time (DOT) > 0.
- TP** This is the Time Profile allocated to a door. When the Time Profile is active, the door will be open allowing "free access". An automatic unlock/lock transaction report will be generated at the beginning and end of the Time Period.
- Lock Mode** This is primarily a feature which the installer will be involved in. The lock mode of the door defines the manner in which the combination of door contact and lock strike operate. Enter 1, 2, 3 ... or 8 to toggle between "-" and the number.



## Explanation of Door Lock Modes

Digit	Function	Not Set (off)	Set (on)
1	Lock Type	Power To Unlock	Power to Lock
2	Door Contact	Door Alarm	Free Exit/EM OVRD
3	RTE Report	Request To Exit	Request For Entry
4	Not Used	Leave in off position	Do Not Use
5	Alarm Module	No K2015 installed	K2015 installed
6	Exit out hours	Not allowed	Allowed
7	Not Used	Leave in off position	Do Not Use
8	Not Used	Leave in off position	Do Not Use

### 1) Lock Type

OFF (-)

The controller will apply power to cause the electronic lock to open the door. The door is secure when no power is applied to the lock.

ON (1)

Power is applied to the lock to secure the door, and power is removed to allow the door to be opened.

### 2) Door Contact

Affect the reports produced and the operation of Request-To-Exit and "Door" contacts.

When OFF (-) the system operates as follows:

**Door Contacts:** The door contacts will perform the usual door alarm monitoring functions. When the door contacts are opened (without an RTE or key use) and a door open time of greater than zero has been set, an appropriate alarm report will be produced. A "Door Left Open" report will be produced as a result of accessing the door and leaving it open, an "Unauthorized Access" report will be generated if the door is forced open.

**Request-to-Exit:** When the RTE button is pressed, the respective door lock will be released and either a "Request to Exit" or a "Request for Entry" report will be produced based on how the RTE Report Type of the door lock mode is set.

When ON (2) the system operates as follows:

**Door Contacts:** When the door contacts are opened, a "Free Exit" report will be produced. Doors fitted with such an option will typically have a handle on one side and a reader on the other. The result of using the handle, for example to get out of a room, will be to generate a "Free Exit" report.

**Request-to-Exit:** When the RTE button is pressed, the report generated will be an "Emergency Override On". When the RTE button is released, the report generated will be an "Emergency Override Off". In this application a standard pull station will probably replace the RTE button. Note that the reports generated here are not effected by how the RTE Report Type of the lock mode is set.

**3) RTE Report** When OFF (-), a "Request to Exit" report will be generated each time the RTE button is pressed.

When ON (3), a "Request for Entry" report will be generated each time the RTE button is pressed.

When the RTE button is being used as an emergency override, e.g. a pull station, the above reports do not apply.

**4) Not Used** Unused, leave OFF (-).

**5) Alarm Module** When OFF (-), an alarm module is not connected to this channel.

When ON (5), an alarm module is connected. It is necessary to specify to the system whether an alarm module is connected to a reader channel so that the system knows which commands to use to light the led on any reader that may be attached or whether or not to produce alarm reports based on activity at the alarm module.

**6) Exit Out Hours** Allows users to exit via this exit door, even though their time profile is inactive.

**7) Not used** Unused, leave OFF (-).

**8) Not Used** Unused, leave OFF (-).

## Door Groups (Doors & Access Menu - 3)

```
Radionics Inc. Readykey K6000-AM: Rev 1.2 v1.2 09:25:30 3/9/92
Door Groups

Door Group Name Doors 1 -16
127
128
1
2
3

- Template

| F1 = | F2 = | F3 = | F4 = | F5 = | F6 = | F7 = | F8 = | F9 = | F10 =
| help | select | | | | >temp | temp> | | print | |
```

Grouping is available in the K6000-AM, but it is not available when editing the K2000-AM from the front panel.

### Description of Door Groups

**Door Group** One of 128 available Door Groups. Grouping enables doors to be assigned quickly to Access Levels.

**Name** Group Name of up to 16 characters.

**Doors 1-16** Any combination of 1 to 16 doors can be assigned to each Door Group. Use commas between door numbers or dashes to signify all doors in a range (e.g., 1,2,7 or 1-5,9,12).

## Access Levels (Doors & Access Menu - 2)

Radionics Inc. Readykey K6000-AM: Rev 1.2 v1.2 09:25:30 3/9/92

### Access Levels

Access Level Name	Group	Group
1	000 -----	000 -----
	000 -----	000 -----
	000 -----	000 -----
	000 -----	000 -----
	000 -----	000 -----
	000 -----	000 -----
	000 -----	000 -----
	000 -----	000 -----
	000 -----	000 -----
	000 -----	000 -----
	000 -----	000 -----
	000 -----	000 -----

- Template

| F1 - | F2 - | F3 - | F4 - | F5 - | F6 - | F7 - | F8 - | F9 - | F10 -  
 | help | select | | | | >temp | temp> | | print | |

### Description of Access Levels

**Access Level** One of 128 levels, each of which can refer to 1 to 20 Door Groups. The Access Level allows the user to assign an Access Level name and specify a combination of Door Groups that make up the Access Level.

**Name** 20 character name for the Access Level.

**Group** The group number (the name is supplied automatically) from the Door Group definitions.

As door group numbers are entered into the Access Level the corresponding group name will be displayed. If a door group number of zero has been entered, then the string, "-----" will be displayed.

## Access Codes (Doors & Access Menu - 1)

Radionics Inc. Readykey K6000-AM: Rev 1.2 v1.2 09:25:30 3/9/92

### Access Code

Access Code	Primary Level	TP	Secondary Level	TP
124	000	00	000	00
125	000	00	000	00
126	000	00	000	00
127	000	00	000	00
128	000	00	000	00
1	001 ALL DOORS	01	000	00
2	000	00	000	00
3	000	00	000	00
4	000	00	000	00
5	000	00	000	00

- Template

| F1 - | F2 - | F3 - | F4 - | F5 - | F6 - | F7 - | F8 - | F9 - | F10 -  
 | help | select | | | | >temp | temp> | | print | |

The access code file refers to the information held in the Access Level and Time Profile files.

### Description of Access Codes

**Access Code** One of 128 Access Codes that refer to the information in the Access Level and Time Profile files.

**Primary Level** One of 128 Access Levels that refer to the Access Level file.

**Primary TP** One of 32 Time Profiles that refer to the Time Profile file. If the TP is OFF, 24 hour access is allowed.

**Secondary Level** One of 128 Access Levels that refer to the Access Level file.

**Secondary TP** One of 32 Time Profiles that refer to the Time Profile file. If the TP is OFF, 24 hour access is allowed.

The use of Primary and Secondary codes allows two distinct combinations to be assigned to one Access Code, providing flexibility and control over access.

If required, Access Levels or Door Groups can be treated as departments, thus breaking the personnel file into more manageable sections. This feature is useful for obtaining a printout of all staff who are allowed access through a particular group of doors.

## Manual Lock/Unlock Doors (Doors & Access Menu - 7)

```
Radionics Inc. Readykey K6000-AM:   Rev 1.2 v1.2 09:25:30   3/9/90

Manual Lock/Unlock

Door                               Manual Lock/Unlock
Ctrlr   Door 1   Door 2   Door 3   Door 4

3   Timed       Timed       Timed       Timed
4   Timed       Timed       Timed       Timed
1   Timed       Timed       Timed       Timed
2   Timed       Timed       Timed       Timed

                                     - Template

| F1 - | F2 - | F3 - | F4 - | F5 - | F6 - | F7 - | F8 - | F9 - | F10 -
| help | select |      |      |      |      |      |      |      |      |
|>temp| temp>|      |      |      |      |      |      |      |      |
```

This allows the operator to manually lock or unlock a door from the K6000-AM, overriding any Time Profile that may be effective on the door at the time.

### Description of Manual Lock / Unlock Doors

The display shows four lines, each representing a door controller. Each line consists of four fields, one for each of the four doors. To change the contents of a field use the up/down arrow keys to select a door and controller. Use **TAB** to select the door. To change the contents of the field, press the **SPACE** bar. The field can contain one of the conditions described below. When the required condition is set, press **ENTER** to confirm.

**UNLOCKED** The door remains unlocked until the LOCKED state is set. However if a Time Profile is active then the UNLOCKED will be cancelled on completion of the Time Profile.

**WARNING!** If no Time Profile is set on the door, then it will remain unlocked until manually locked again.

**LOCKED** This can be used to override an active Time Profile and remains in effect until changed by the Editor.

**TIMED** This is the normal state for a door to be in whether or not a Time Profile has been set against it. That means it is now back under the control of any existing Time Profile. The Timed display does not automatically reappear after a Time Profile regains control of a manually locked or unlocked door.

**Note:** The LOCKED condition does not override the normal means of gaining access - via RTE or Electronic Key. Neither does it stop an Emergency Override from activating the lock.

## Event Analysis Menu (Main Menu - 6)

Radionics Inc. Readykey K6000-AM: Rev 1.2 v1.2 09:25:30 3/9/92

### EVENT ANALYSIS MENU

- |                              |                               |
|------------------------------|-------------------------------|
| 1 - Historical Transactions  | 5 - Print Current User Report |
| 2 - Muster Mode              | 6 - Personnel Trace           |
| 3 - Presence in Area         | 7 - Editor Audit Trail        |
| 4 - Void Personnel From Area |                               |

Selection:

Event Analysis Menu

## Historical Transactions (Event Analysis Menu - 1)

```
Radionics Inc. Readykey K6000-AM:   Rev 1.2 v1.2   09:25:30   3/9/92

      Historical Transactions

      ON/      Name      ID   Door Trans
      OFF
  6   OFF
  7   OFF
  8   OFF
  9   OFF
 10  OFF
  1   OFF
  2   OFF
  3   OFF
  4   OFF
  5   OFF

                                     - Template

| F1 - | F2 - | F3 - | F4 - | F5 - | F6 - | F7 - | F8 - | F9 - | F10 -
| help | select |      |      | >temp | temp> |      | print | dates |
```

This allows a search to be performed based on data that is present in the K6000-AM files.

### Description of Historical Transaction Analysis

Up to 10 selection criteria may be entered.

<b>ON/OFF</b>	ON/OFF acts as a switch (space bar to toggle). If set to OFF, the search for that criterion will not be carried out. Up to 10 criteria can be specified. More than one criterion can be selected simultaneously.
<b>Name</b>	Keyholder's identification (optional).
<b>ID</b>	Personnel record number (entry of 0 = all personnel).
<b>Door</b>	Select access points (entry of 0 = all doors).
<b>Trans Type</b>	Search for a given transaction report (entry of 0 = all transactions). See <i>Transaction Types</i> beginning on page 66.



## To Analyze the History

1. Establish the search parameters.
2. Press F9.
3. Enter the Start and End dates and times for the search period. You will be prompted to insert an archive transaction disk if the transactions required are prior to those resident on the system hard disk.
4. Press F9. The search will commence on the criteria which have "ON" selected and report to the printer.

### Muster Mode (Event Analysis Menu - 2)

Radionics Inc. Readykey K6000-AM: Rev 1.2 v1.2 09:25:30 3/9/92

#### EVENT ANALYSIS MENU

- |                              |                               |
|------------------------------|-------------------------------|
| 1 - Historical Transactions  | 5 - Print Current User Report |
| 2 - <b>Muster Mode</b>       | 6 - Personnel Trace           |
| 3 - Presence in Area         | 7 - Editor Audit Trail        |
| 4 - Void Personnel From Area |                               |

Selection:

Once selected, this option places the K6000-AM in a special mode in which the K6000-AM will print all "Exit" and "Entry Authorized", and "Access Authorized" transactions taking place at certain pre-selected readers or 'Muster Points' (see the PC Configuration Menu section beginning on page 60).

This provides a means of accounting for personnel in the event of an emergency evacuation from a building.

"Muster Mode Enabled" or "Muster Mode Disabled" will be displayed momentarily. The transaction monitoring display will show "System in Muster Mode".

## To Select the Muster Mode

In the event of an emergency the operator should perform the following:

1. Select the Muster Mode from the Event Analysis menu.
2. Escape from the editor. A yellow prompt appears at the bottom of the transaction screen.

Personnel present their ID keys to pre-determined readers. The system can then generate a printed report of those people who have left the building in the following format:

Muster Printout for Site: MAIN OFFICE -Taken:04/20/92 13:01:06			
Time	ID	Name	Muster Point
13:01	3500	THE MASTER EDITOR	DOOR 9
13:01	V003	NORTH, JANE	DOOR 9
13:01	3600	SMITH, JOE	DOOR 9
13:01	3800	JONES, ROGER	DOOR 9
13:01	3700	PATH, MARY ANN	DOOR 9

Muster Mode is cancelled by re-entering the editor.

**Note:** All non-access transaction reports and all reports from the non-muster points will appear on the screen but will not reach the printer.

Alarm reports will still require acknowledging by the operator, however these reports will not be sent to the printer even on cancelling the muster mode. It is therefore necessary to retrieve them by Historic Analysis (option 1) of the Event Analysis Menu.

Monitored Areas and Muster Points must be defined for Muster Mode to operate. See the PC Configuration Menu, page 61.

EVENT ANALYSIS MENU

- |                              |                               |
|------------------------------|-------------------------------|
| 1 - Historical Transactions  | 5 - Print Current User Report |
| 2 - Master Mode              | 6 - Personnel Trace           |
| 3 - Presence in Area         | 7 - Editor Audit Trail        |
| 4 - Void Personnel From Area |                               |

Selection:

### Presence in Area (Event Analysis Menu - 3)

This option allows the operator to request a print out of all personnel in a specified area.

#### Application

Typical uses are areas that have potentially dangerous chemicals, or restricted areas. In cases where safety or security are essential, the Presence in Area facility indicates who is in the area of question at the current time.

The actual area to be monitored is defined using doors specified as entry doors and exit doors. These are set up during the installation configuration of the K6000-AM. See the PC Configuration Menu Define Monitored Areas, page 61.

## Void Personnel from Area (Event Analysis Menu - 4)

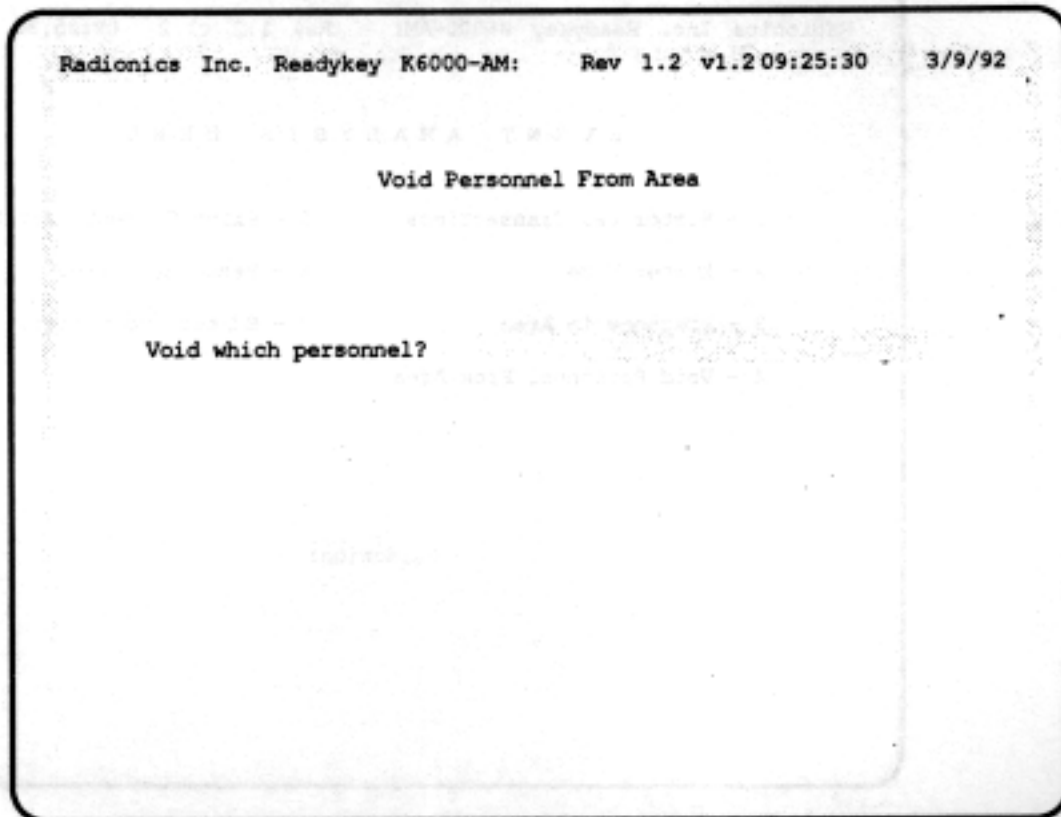

This option is used to clear the indicator that is used to record the presence of an individual in a monitored area.

### Application

The K6000-AM may wrongly report that personnel may be in a monitored area due to individuals not presenting their ID key to the reader because the door was held open by a colleague to allow a number of people to leave together. To correct this situation, the presence in area flags can be cleared.

### To Void Personnel from an Area

1. Select option 4 of the Event Analysis menu.
2. Type the IDs of those flags that are to be cancelled (1-3, 523). Press ENTER. Typing in "All" will void all keys from the area.
3. Press ESC to return to the Event Analysis menu.

**Note:** Where a range of IDs are sequential, the range of numbers can be quickly entered by typing the lowest and highest IDs of the range separated by a hyphen (-).

The Monitored Area is set up in the PC Configuration Menu, page 60.

## Print Current User Report (Event Analysis Menu - 5)

```
Radionics Inc. Readykey K6000-AM:   Rev 1.2 v1.2 09:25:30   3/9/92

Current User

Auto   Time of   Days After
Report Report   KEYS Used

1      OFF      00:00      01

- Template

| F1 - | F2 - | F3 - | F4 - | F5 - | F6 - | F7 - | F8 - | F9 - | F10 -
| help | select |      |      | >temp | temp> |      | print | report |
```

This report may be used by the operator to obtain a list of all personnel who have not used their key over a specified number of days. This printout may be obtained manually at anytime, or produced automatically at a time the user programmed. The advantage of this report is its ability to detect users who no longer use their keys.

### Programming for the New Report

The "AUTO REPORT" field may be set to ON or OFF. OFF indicates that an automatic report should not be made. If set to ON then the current user report will be automatically made at the time of day indicated in the field labeled "TIME OF REPORT".

The field labeled "DAYS AFTER KEYS USED" holds the number of days that the keyholder may be allowed not to use their key before being reported. For example, if this field contains "02", then the system will print out all those personnel who have not used their key for two days or more.

### Obtaining the Report

The Current User Report can be obtained manually at anytime by pressing F9 when the Current User Report record is being displayed. Note that after obtaining a manual report, the automatic report (if enabled) will not be produced later that same day.

The Current User Report may also be obtained automatically each day by programming the required parameters into the Current User Report record. This record can be obtained by choosing Option-5 of the Transaction Analysis menu. Having obtained the record, the user should program in the time of day for the report to occur (in 24-Hour format) into the field labelled "TIME OF REPORT". The user should also check that auto reporting is enabled.

Please note that the Automatic Report will not be given at the specified time until the transaction screen is displayed. Nor will it be produced if the printer is off line, out of paper or switched off.

## Personnel Trace (Event Analysis Menu - 6)

```

Radionics Inc. Readykey K6000-AM:   Rev 1.2 v1.2 09:25:30   3/9/92

      Personnel Trace

Trace   Trace to
ON?     Printer?

1       OFF       NO

                                     - Template

| F1 - | F2 - | F3 - | F4 - | F5 - | F6 - | F7 - | F8 - | F9 - | F10 -
| help | select |      |      | >temp | temp> |      | print | report |
  
```

The personnel trace allows the system operator to 'tag' keys. Tagging keys highlights their movements on the screen or sends events to the printer as they occur.

### Description of Personnel Trace

**Trace ON/OFF**    ON = Enable Trace. OFF = Disable Trace. (Toggle ON/OFF with SPACE bar.)

**Trace to Printer**    NO = Output event to screen only (in a different color).

YES = Output events to screen and printer; "\*" appears against traced events at the printer. This selection of the type of trace is only done once. From then on, keyholders requiring a trace are selected by entering the Personnel or Visitor file and pressing SHFT/F2 at each record selected for a trace. These records are identified by an asterisk beside the keyholder field.

The trace may be cancelled by pressing **SHFT/F2** on a 'tagged' field. The asterisk will disappear. At the transaction screen, the bottom blue bar will indicate that a trace is in operation.

**Note:** If muster mode is invoked, the trace facility is overridden.

## Editor Audit Trail (Event Analysis Menu - 7)

```

Radionics Inc. Readykey K6000-AM:   Rev 1.2 v1.2 09:25:30   3/9/92

      Editor Audit Trail

      ON/      Editor      Editor  Update
      OFF      Name       ID      Type
6      OFF
7      OFF
8      OFF
9      OFF
10     OFF
1      OFF
2      OFF
3      OFF
4      OFF
5      OFF

                                     - Template -

| F1 - | F2 - | F3 - | F4 - | F5 - | F6 - | F7 - | F8 - | F9 - | F10 -
| help | select |      |      | >temp | temp> |      | print | report |
  
```

This allows actions taken by Editor Keys in the K6000-AM Editor to be displayed to the printer or screen.

### Description of Editor Audit Trail

Up to 10 criteria may be selected.

- OFF/** This filter will not be used (use **SPACE** bar to toggle).
- ON** This filter will be active.
- Editor Name** Enter the Editor name (optional).
- Editor ID** Enter the System Operator number (1-33) or 0 for all operators.  
33 = Master Key.

**Update Type**

One of the following:

0	All update types	20	Analysis Records
1	Personnel	21	Transaction Dates
2	Not used	22	Muster Points
3	Visitors	23	Area Presence
4	Not used	24	Report Parameters
5	Not used	25	Print Limit
6	Holiday Profiles	26	Door Groups
7	Holiday Periods	27	Access Limit
8	Alarm Messages	28	Not used
9	Editor Records	29	Not used
10	Not used	30	Transaction Routing
11	Not used	31	Route Times
12	Passback Codes	32	Poll Table
13	Access Code	33	Relay Control
14	Not used	34	Recording Control
15	Access Points	35	Door Exclusion
16	Time Profiles	36	Personnel Trace
17	Time Periods	37	Editor Audit Trail
18	Alarm Responses	38	Audit Dates
19	Alarm Sensors	39	Not used

**To Analyze the Editor Audit Trail**

1. Establish the search parameters.
2. Press **F9**.
3. Enter the Start and End dates for the search period. You will be prompted to insert an archive transaction disk if the transactions required are prior to those resident on the system hard disk.
4. Press **F9**. The search will commence on the criteria which have "ON" selected.
5. Press **ESC** to return to the Audit Trail Analysis screen.

**F10** toggles between output of information to the printer, file or the screen. If output to file is selected, the file TRACE.DAT is created.

The description indicates the Editor key, time and date, file affected and a representation of the record change, describing what the field previously stored and what it was changed to.



# System Configuration Menu (Main Menu - 7)

Radionics Inc. Readykey K6000-AM: Rev 1.2 v1.2 09:25:30 3/9/92

## S Y S C O N F I G M E N U

- 1 - System Editor Data
- 2 - Door Control
- 3 - Download to all Controllers
- 4 - Synchronize System Clocks
- 5 - Poll Table
- 6 - Data Protection Menu
- 8 - Installation Configuration

Selection:

### System Configuration Menu

## System Editor Data (Sys Config Menu - 1)

Radionics Inc. Readykey K6000-AM: Rev 1.2 v1.2 09:25:30 3/9/92

### Editors

Editor	Name	Password	Editor Level
28			0000000000000000
29			0000000000000000
30			0000000000000000
31			0000000000000000
32			0000000000000000
1	TOM JONES	T	1000000011111111
2	ED BROWN, NT GUARD	T	0000000000000000
3			0000000000000000
4			0000000000000000
5			0000000000000000

- Template

| F1 = | F2 = | F3 = | F4 = | F5 = | F6 = | F7 = | F8 = | F9 = | F10 =  
| help | select | | | | >temp | temp> | | print | add | void

There may be up to 32 editors. Each editor has a name, password, and editor level selection. The level consists of 16 bits, each bit representing access to a function. Currently bits 1 and 9 - 16 are used. Setting a bit to 1 allows access, while setting to 0 prevents access. Bits 16 - 9 represent menu functions from the main menu (1-8) respectively. Bit 1 gives the editor access to displaying PIN codes of keys.

Enter the name first, then the key. The editor level is cleared to 0 when the key is entered. Enter the editor level last.

**Note:** When a key is entered into this database it becomes an Editor. This does not mean it will open any doors. If the opening of doors is also required, the key must also have its code assigned in the Personnel Database in the same way as other keys do.

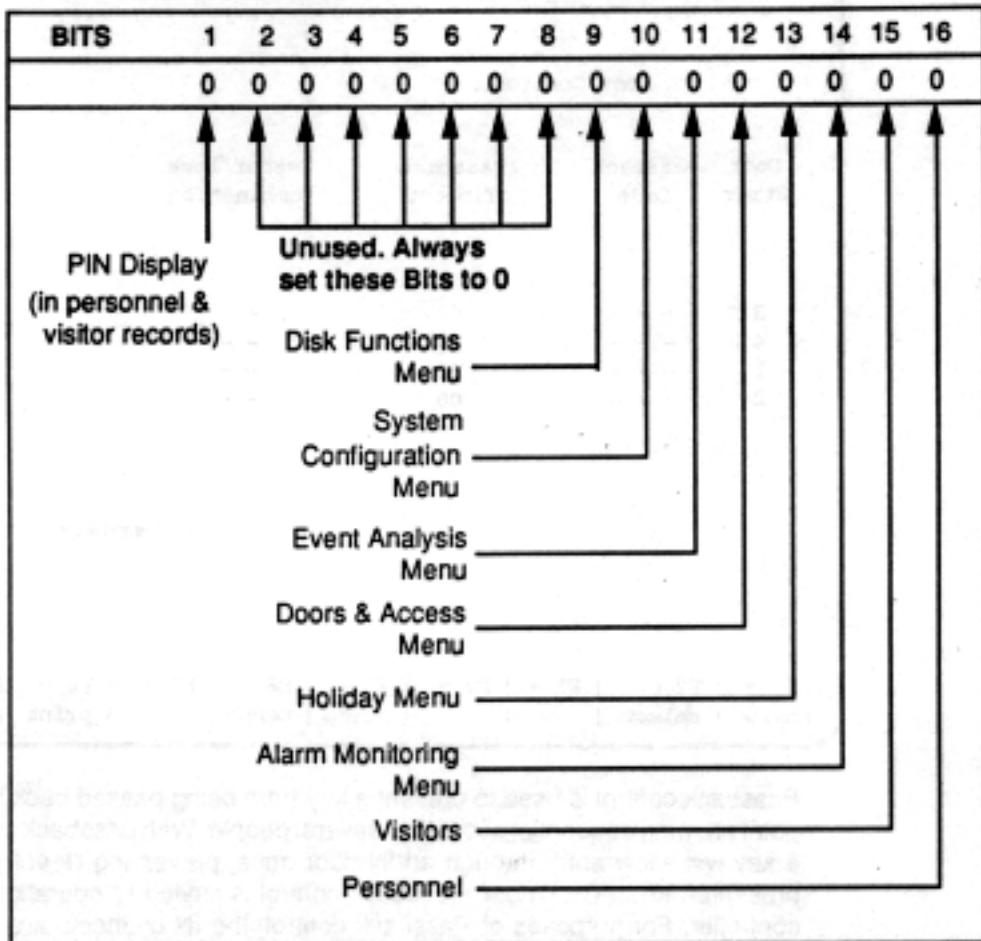

**Editor Level Chart**

## Door Control (Sys Config Menu - 2)

```
Radionics Inc. Readykey K6000-AM: Rev 1.2 v1.2 09:25:30 3/9/92

Door Control

Door Ctrlr  Passback Code  Passback Timeout  Reader/Lock
Combination

3  - - -  00  - -
4  - - -  00  - -
1  - - -  00  - -
2  - - -  00  - -

- Template

| F1 = | F2 = | F3 = | F4 = | F5 = | F6 = | F7 = | F8 = | F9 = | F10 =
| help | select | | | >temp | temp> | | print | |
```

Passback control is used to prevent a key from being passed back through an access point allowing sequential access for several people. With passback control in operation, a key will allow entry through an IN door once, preventing re-entry until it has been presented to an OUT door. Passback control is limited to operation on a single door controller. For purposes of Passback control, the IN channels are 1 and 2; the OUT channels are 3 and 4. Place the cursor in the Passback Code field, and use the number keys 1 and 2 to set/reset the Passback Code to the required value as shown below.

### Description of Door Control

<b>Door Ctrlr</b>	1, 2, 3 or 4.
<b>Passback Code</b>	1- - To set Passback on channel 1 (channel 4 is the exit door).
	-2- To set Passback on channel 2 (channel 3 is the exit door).
	12 - To set Passback on channels 1 and 2 (channels 3 and 4 are exit doors).

In a similar way to control passback on entry, it is possible to prevent repeated use of the key on an EXIT reader. To control the passback on exit, place the cursor anywhere in the Passback Code field and press the 3. A "T" is displayed in the third position. If a door contact is installed and the door monitoring is setup (i.e., door open time > 0), the Passback restriction is not started until the door is opened.

### Passback Time-out

Under normal circumstances the passback control remains in force indefinitely. For example, if Passback control is set on doors 2 and 3, and a key is presented to door 2, that key cannot be used again on door 2 until it has been presented at door 3. It is often required to set the Passback control if the chances of someone leaving a protected area without presenting their key (e.g., leaving with someone else) are high. Using the timeout facility in this instance enables the person to re-enter the area after completion of the timeout cycle.

To set the Time-out period (10-30 minutes), place the cursor in the Passback Timeout field and insert a number representing the timeout in minutes. Any number between 10 and 30 will enable the facility. An entry of 0 represents no timed forgive.

**Note:** An Emergency Override will not cancel Passback and may require a Void Personnel from Area command.

### Reader/Lock Combination

In addition to programmable Passback control, a channel linking facility, allowing channels 1 and 4 to operate lock output 1, and channels 2 and 3 to operate lock output 2. Place the cursor in the Reader/Lock Combination field and use the number keys 1 and 2 to set/reset the to the required value as shown below.

To set reader combination 1 and 4 to operate lock 1	1-
To set reader combination 2 and 3 to operate lock 2	-2
To set both combinations	12

In the case of linked readers, the door contact and request to exit input are also linked and should be fitted as follows.

Readers 1 and 4 linked - door contact wired to door 1.  
Readers 2 and 3 linked - door contact wired to door 2.

## Download to all Door Controllers (Sys Config Menu - 3)

Radionics Inc. Readykey K6000-AM: Rev 1.2 v1.2 09:25:30 3/9/92

### DATABASE DOWNLOAD

**WARNING - This Download is to all Door Controllers**

Are You SURE?

This allows the editor of the system to send a copy of the databases to all door controllers. This is useful if a Door Controller had been taken off line for any reason. A Download updates the contents of all door controllers to that stored in the K6000-AM. A special download file is generated by the system and passed to the K2000-AM for distribution to all door controllers including itself.

Once the download file has been generated the user is returned to the Editor while the download continues transparently. The percentage of the download to the K2000-AM is displayed.

A download must be completed before the system will allow another download to be started. The progress of the download is displayed on the K6000-AM screen. Always INITIALIZE a new door controller prior to a download.

**Note:** At least one personnel record must be programmed before a download.

## Synchronize System Clocks (Sys Config Menu - 4)

Radionics Inc. Readykey K6000-AM: Rev 1.2 v1.2 09:25:30 3/9/92

### S Y S C O N F I G M E N U

- |                                      |                                |
|--------------------------------------|--------------------------------|
| 1 - System Editor Data               | 5 - Poll Table                 |
| 2 - Door Control                     | 6 - Data Protection Menu       |
| 3 - Download to all Controllers      | 8 - Installation Configuration |
| 4 - <b>Synchronize System Clocks</b> |                                |

Selection:

This function allows the K2000-AM and all the door controllers time keeping clocks to be set to that of the K6000-AM. This will be done automatically at system start-up, 12 o'clock midday and midnight by the K6000-AM, but will need to be done manually at Daylight Savings Time changeovers. The K2000-AM will beep several times to acknowledge the clock sync command.

## Poll Table (Sys Config Menu - 5)

```
Radionics Inc. Readykey K6000-AM:   Rev 1.2 v1.2 09:25:30   3/9/92

Poll Table

Door Controller
Addresses

1 ---

- Template

|F1 = | F2 = | F3 = | F4 = | F5 = | F6 = | F7 = | F8 = | F9 = | F10 =
|help | select | | | | >temp | temp> | | print | |
```

The address of each Door Controller attached to the K2000-AM is entered here. Satisfactory communication/polling is indicated for each controller on the Transaction Monitoring Screen.

To insert an address, (2,3 or 4; address 1 is automatically allocated to the K2000-AM), press the number keys 2,3 or 4 while the cursor is any part of the address field, then press **ENTER**.



## Data Protection Menu (Sys Config Menu - 6)

Radionics Inc. Readykey K6000-AM: Rev 1.2 v1.2 09:25:30 3/9/90

### DATA PROTECTION MENU

- 1 - Recording Control
- 2 - Door Exclusion
- 3 - Delete Transaction Data

Selection:

Due to the increasingly widespread use of computers as large data retrieval systems, some governments have introduced data protection acts. Most data protection acts apply not just to personal computers and mainframes, but to anything storing data which can be directly or indirectly linked to a specific person; this includes access control systems.

The K6000-AM offers features for controlling when, what and how transactional information is recorded/printed/displayed. Old transaction data that is no longer required may be deleted.

### Description of Data Protection

#### Recording Control

- Control of when personal transactions are stored, displayed and printed.
- Control of what type of personal transactions are stored, displayed and printed, i.e. valid or invalid access attempts.

#### Door Exclusion

- Control over which doors transaction reports are stored or displayed.

#### Delete Transaction Data

- Deletion of unwanted transaction information.

There are two types of reports that can be produced relating to personnel transactions: negative and positive reports. Positive reports are authorized access attempts. Negative reports are invalid access attempts. Each type of report is shown as follows:

**Positive Reports**

- Type 1 - "Exit Authorized"
- Type 2 - "Entry Authorized"
- Type 3 - "Access Authorized"

**Negative Reports**

- Type 10 - "No Access: Level"
- Type 11 - "No Access: Locked Out"
- Type 12 - "No Access: Time"
- Type 13 - "No Access: Passback"
- Type 14 - "No Access: Holiday"
- Type 32 - "No Access: Visit Time"

**Recording Control (Data Protection Menu - 1)**

```

Radionics Inc. Readykey K6000-AM:      Rev 1.2 v1.2 09:25:30      3/9/92

Recording Control

Transaction      POS/      TP
Switch           NEG

1      ON      POS      00

- Template

| F1 = | F2 = | F3 = | F4 = | F5 = | F6 = | F7 = | F8 = | F9 = | F10 =
| help | select |      |      | >temp | temp> |      | print |      |
    
```

**Description of Recording Control**

- Transaction Switch** This field can be toggled ON/OFF using the space bar.
- OFF Indicates that all personal transactions whether negative or positive will not be recorded.
  - ON Indicates that all transactions (types depending on the setting of POS/NEG) will be recorded.
- POS/NEG** This field can be toggled between POS and NEG using the space bar.
- NEG Allows only negative type personal transactions will be recorded, providing the ON/OFF field is set to ON.
  - POS Means that all personal transactions are recorded, provided that the ON/OFF field is set to ON.

TP

Specifies a Time Profile for personal transaction recording purposes. A Time Profile number of 0-32 should be entered here.

When the Time Profile is not active, personal transaction recording will be inhibited. When the Time Profile is active, personal transaction recording will occur as long as the Transaction switch is set to ON.

It is recommended that a separate Time Profile (i.e., not one used for doors, personnel, etc.) should be set aside for transaction recording control. If timed transaction control is not required, the TP field should contain zero.

## Door Exclusion (Data Protection Menu - 2)

Radionics Inc. Readykey K6000-AM: Rev 1.2 v1.2 09:25:30 3/9/92

Door Exclusion

Door Numbers to be Excluded

1

- Template

| F1 - | F2 - | F3 - | F4 - | F5 - | F6 - | F7 - | F8 - | F9 - | F10 -  
| help | select | | | >temp | temp> | | print | |

### Description of Door Exclusion

Excludes personal transaction reports - positive and negative - being generated for certain doors in the system. Normally, these will be high activity doors such as a main entrance. A list of door numbers may be entered separated by commas or spaces. Dashes may also be used to represent a range of doors.

Door alarms and unknown keys will still be reported.

## Delete Transaction Data (Data Protection Menu - 3)

```
Radionics Inc. Readykey K6000-AM: Rev 1.0 v1.1 09:25:30 3/9/90

Date Range

Start Period      End Period
Date / Time      Date / Time

1  00/00/00 00:00  00/00/00 00:00

- Template

| F1 = | F2 = | F3 = | F4 = | F5 = | F6 = | F7 = | F8 = | F9 = | F10 =
| help | select |      |      | >temp | temp> |      | print | delete |
```

### Explanation of Delete Transaction Data

Allows the deletion of all personal transactions - positive and negative - between a start and end date. Once the two required dates have been entered, press F9 to start a search of all recorded transactions to be voided from the system. There must be a record with a valid starting date.

Voiding of personal transactions is carried out by the system erasing any personnel/visitor name or ID held against the transaction. Once all the specified transactions have been erased, the system will return to the Data Protection menu.

## Installation Configuration Utility (Sys Config Menu - 7)

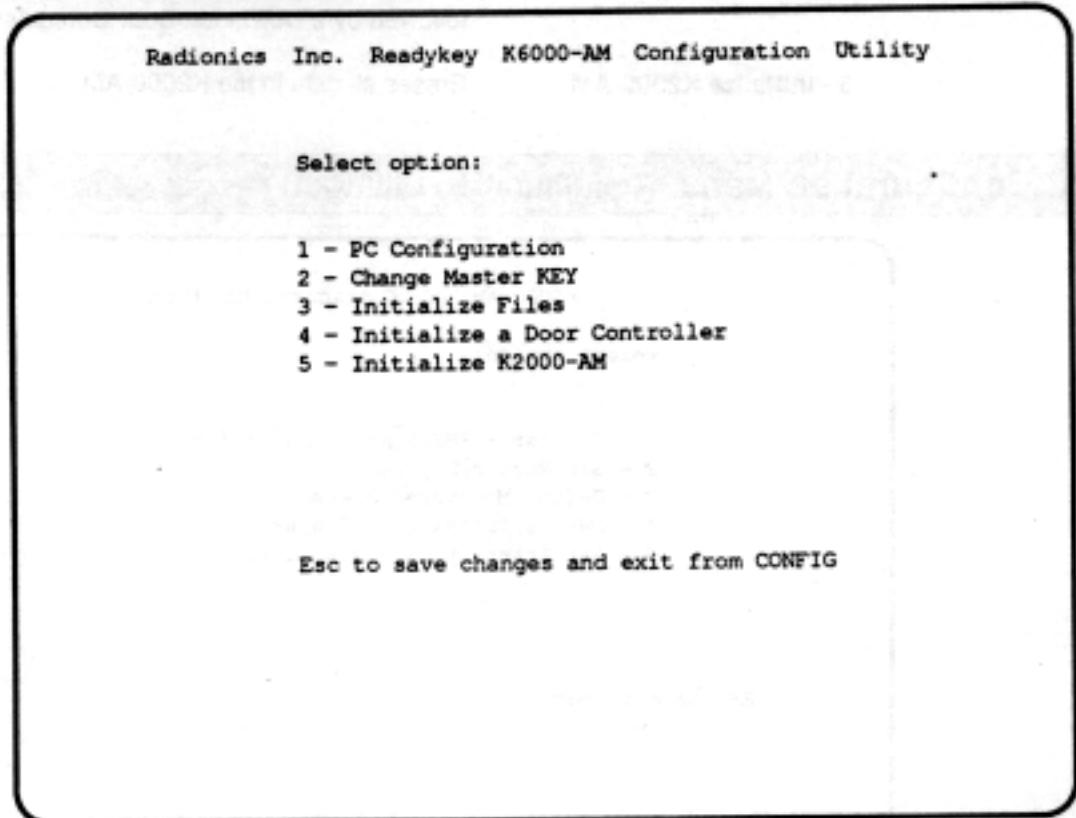

The K6000-AM system comes with two versions of the Configuration Utility program.

The CONFIG.COM program is run immediately after the software is initially installed. It can also be executed from MS DOS by typing A:CONFIG while in the C:\AM2000 directory and the relevant distribution disk is in Drive A:. This form of the configuration utility has been provided so that installers can assign a new master key to the system. If the file CONFIG.MD2 is deleted from drive C: and the system configuration is selected, the error message "CONFIG MODULE NOT PRESENT" will appear on the screen and you will not be able to use this menu.

### Description of the Installation Configuration Utility Menu

#### 1 - PC Configuration

When selected, this puts the user into a new sub-menu for setting up PC characteristics. (See *Description of PC Configuration Menu*).

#### 2 - Change Master Key

This allows a new master key to be assigned. Press 2; present the key that will become the master key to the PC READER. Enter a password (optional). Press ENTER.

#### 3 - Initialize Files

**Will erase all data files, such as alarm messages, personnel files, visitor files etc. Use this command with care.**

- 4 - Initialize Door Controller** Erases all data in the door controller. You will be prompted to enter the address (2, 3 or 4) of the door controller you want to clear. This command is normally followed by a Download Door Controller command.
- 5 - Initialize K2000-AM** Erases all data in the K2000-AM.

## PC Configuration Menu (Configuration Utility - 1)

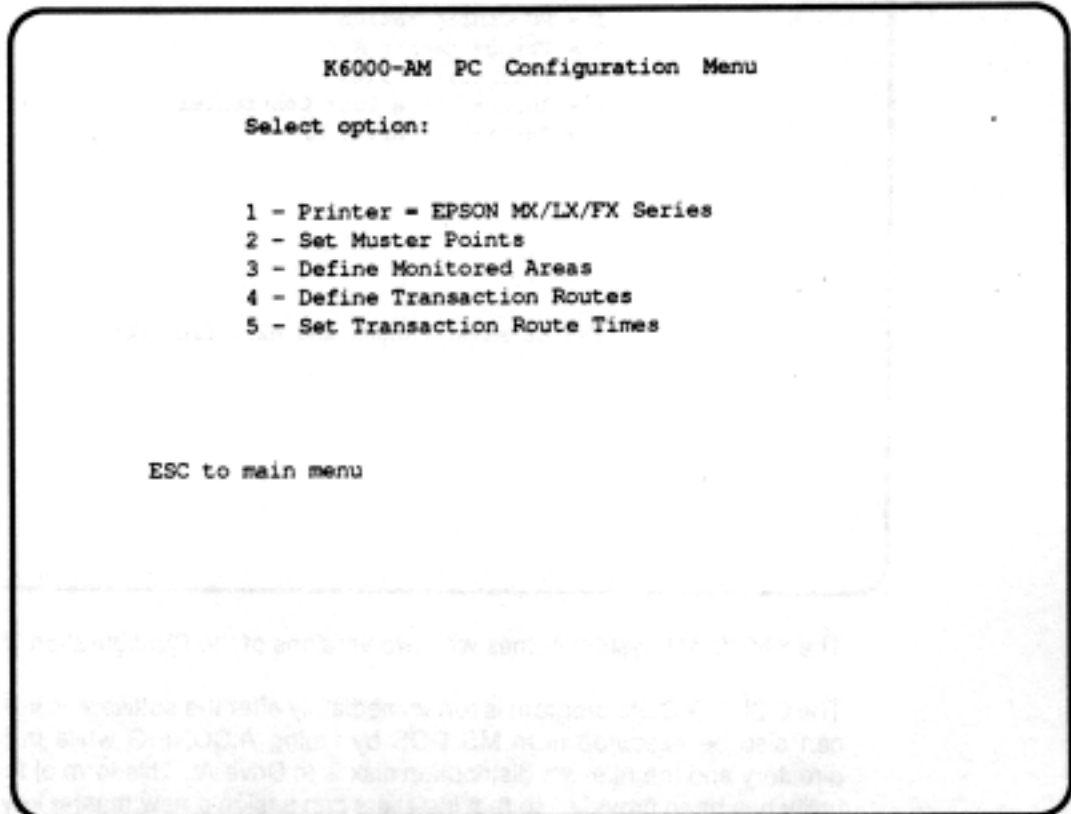

### Description of PC Configuration Menu

- 1 Printer = EPSON MX/LX/FX Series**  
Define what type of parallel printer is in use at the master PC. Press 1 to change between EPSON MX/LX/FX series and MICROLINE 182/192 series printers.
- 2 Set Muster Points and**
- 3 Define Monitored Areas**  
Assigns readers with special monitoring functions for purposes of muster or identifying personnel within an area bounded by reader points. Enter commas between individual doors and a dash for door ranges (e.g., 1,2,3 or 1,2,5-7).
- 4 Define Transaction Routes**  
This facility determines whether a transaction is displayed on the screen or printer and, if it is an alarm condition, whether it should be acknowledged. In addition, it can be determined whether a transaction is displayed on the screen in white or red. Routing frames are used to determine where each of the 48 different type of transactions are sent. Each frame takes two screens and up to 8 frames can be set. Each frame can have a Time Profile set. This allows different transaction reporting for day and night.

When the transaction route frame is displayed the up and down arrow keys switch between the two parts of each frame and from one frame to another. The frame number is displayed at the top of the screen. Use the TAB key to move from one transaction to another.

To select transaction routing options, press the 1, 2, 3, and 4 keys to switch ON and OFF S, P A, and R respectively.

- S** sends the transaction to the screen.
- P** sends the transaction to the printer.
- A** indicates that alarms (Items marked with an asterisk) need to be acknowledged at the PC reader.
- R** sets the color of transactions sent to the screen to red, if not set they will be in white.

**Note:** Transactions are always stored even though they may not be displayed at the time they occur (unless the events are controlled by Recording Control in the Data Protection Menu).

#### Transaction Route Configuration

Routing Frame: 1

Description	Route	Description	Route
Exit Authorized	S - - -	No Entry: Passback	S P - R
Entry Authorized	S - - -	No Access: Holiday	S P - R
Access Authorized	S - - -	Door Left Open	S P - R
Free Exit	S - - -	Door Closed	S P - R
Emergency Override On	S P - R	Anti-Tamper Alarm	* S P A R
Emergency Override Off	S P - R	Alarm Cleared	S - - -
Request to Exit	S - - -	Override Alarm	* S P A R
Request for Entry	S - - -	Override Alarm Reset	S - - -
Unauthorized Access	* S P A R	Manual Lock	S - - -
No Access: Level	S P - R	Manual Unlock	S - - -
No Access: Locked Out	S P - R	Automatic Lock	S - - -
No Access: Time	S P - R	Automatic Unlock	S - - -

Transaction Route Configuration

Routing Frame: 1

Description	Route	Description	Route
Editor Off	S - - -	Override Alm Accepted	S - - -
Editor On	S - - -	RTE Button Held Down	S P - R
Alarm Activated	* S P A R	Repeat Token Use	S P - R
Sensor Reset	S - - -	Unused	- - - -
Automatic Isolate	S - - -	Unused	- - - -
Automatic Engage	S - - -	Unused	- - - -
Local Alarm Accept	S - - -	Unused	- - - -
No Access: Visit Time	S P - R	Unused	- - - -
No Access: Unknown ID	S P - R	No Exit:Passback	S P - R
Manual Isolate	S P A R	Exit Out of Hours	S P - R
Manual Engage	S - - -	Editor Off (Panel)	S - - -
Alarm Acknowledged	S - - -	Editor On (Panel)	S - - -



## 5 Set Transaction Route Times

This facility allows different transaction routes to be set at different times, or manually switched on and off. Use the **TAB** key to move between fields. Use the **SPACE** bar to switch between ON and OFF and enter a number between 0 and 32 for the Time Profile.

An entry of 00 in Time Profiles specifies 24 hours per day, seven days per week. If two route frames have overlapping Time Profiles, the lower number Route Frame is used.

### Transaction Routing Times

Route Frame #1	: Enable = ON	Time Profile = 00
Route Frame #2	: Enable = OFF	Time Profile = 00
Route Frame #3	: Enable = OFF	Time Profile = 00
Route Frame #4	: Enable = OFF	Time Profile = 00
Route Frame #5	: Enable = OFF	Time Profile = 00
Route Frame #6	: Enable = OFF	Time Profile = 00
Route Frame #7	: Enable = OFF	Time Profile = 00
Route Frame #8	: Enable = OFF	Time Profile = 00

## Disk Functions Menu (Main Menu - 8)

Radionics Inc. Readykey K6000-AM: Rev 1.0 v1.1 09:25:30 3/9/90

### D I S K F U N C T I O N S M E N U

- |                               |                                    |
|-------------------------------|------------------------------------|
| 1 - Format a Diskette         | 5 - Backup Master Transaction File |
| 2 - Save System Database      | 6 - Execute a DOS Command          |
| 3 - Restore System Database   | 7 - Escape from K6000-AM System    |
| 4 - Archive Transaction Files |                                    |

This enables the user to carry out computer operating system commands without leaving the K6000-AM system.

## Format A Diskette (Disk Functions Menu - 1)

This command allows the normal DOS diskette format command to be run from inside the K6000-AM program. All new diskettes used on a computer must be formatted before use. The function assumes the disk is to be formatted in the system A: drive, and that DOS is installed (and the format command is in the path).

## Save System Database (Disk Functions Menu - 2)

This command writes all data files to an already formatted diskette inserted in the system A: drive. It is good practice to save the system database every time any significant changes are made to the system database. Multiple diskettes should be used, these being rotated between each database save. This way, even if one diskette gets lost or corrupted there is always a previous back up available. Transactions are not backed up.

## Restore System Database (Disk Functions Menu - 3)

This command reloads the data files from a diskette in the system A: drive onto the system hard disk (C:\AM2000).

## Archive Transaction Files (Disk Functions Menu - 4)

This function copies archived transaction files on the system hard disk to diskette for archive storage. The function is automatic once invoked and will prompt for insertion of diskettes as required. It is essential that each diskette is marked with the disk number and date, and stored in a safe place for later use for data retrieval if needed.

## Backup Master Transaction File (Disk Functions Menu - 5)

This facility saves the current TRANS.DAT file onto diskette. After selecting option 5, the following message will appear on the screen:

```
READY TO BACKUP TRANS.DAT
INSERT BACKUP DISKETTE IN DRIVE A:
PRESS ANY KEY TO CONTINUE
```

After the user has inserted a formatted diskette into the system A: drive and pressed a key, the system will check that there is enough room on the diskette to backup the transaction file. If the diskette does not contain enough free space, the system will display the following message.

```
NO ROOM ON DISKETTE - REPLACE AND PRESS ANY KEY TO CONTINUE
```

Once copying starts, the following message is displayed:

```
COPYING ARCHIVE FILE TRANS.DAT TO DISK A
```

When the backup is finished, the system displays the message:

```
TRANS.DAT COPIED TO DISK A:
REMOVE DISKETTE AND PRESS ANY KEY TO CONTINUE
```

On pressing a key, the system will return to the Disk Functions Menu.

**Note:** This backup is to save transactions that have not yet been archived. In the event that a problem occurs on the system computer that requires the disk to be restored, copy the file TRANS.DAT back onto the C:\2000AM directory from the diskette to restore these transactions.

## Execute a DOS Command (Disk Functions Menu - 6)

To carry out any command described in the DOS manual. DOS must be in the path.

## Escape from K6000-AM System (Disk Functions Menu - 7)

This stops the K6000-AM program, releasing it to do other functions. However, the K2000-AM, and all controllers connected to it continue to operate as normal. Reinvoking the K6000-AM program will pick up the transactions as normal. A form feed is sent to the printer.

## Transaction Types

The following provide an explanation for transactions which may appear in Transaction column of the Transaction Monitoring display:

1. Exit Authorized            An exit door was opened with a key.
2. Entry Authorized        If an ID and name are reported, an entry door was opened with a key. If no name or ID are reported, an entry door was opened using the RTE button.
3. Access Authorized      A door, not designated as entry or exit, was opened using a key.
4. Free Exit                A door was opened from the inside using the door handle.
5. Emergency Override On    The monitored pull station associated with a door has been struck. The door is no longer secure. This event may require editor acknowledgement, and is printed as an exception.
6. Emergency Override Off    The monitored pull station associated with a door has been repaired. This is printed as an exception.
7. Request to Exit         An exit door was opened using the RTE button.
8. Request for Entry        An entry door was opened using the RTE button.
9. Unauthorized Access     A door has been forced open.
10. No Access: Level        The key used has not been assigned access to this particular door.
11. No Access: Locked Out    The key used has not been assigned access to any door.
12. No Access: Time        The key has been used outside of its assigned Time Profile.
13. No Access: Passback    An attempt has been made to access an entry (or exit) door without exiting (or entering) first.
14. No Access: Holiday     The key used is assigned an active holiday profile.
15. Door Left Open         A door has been left open for longer than its specified "door open time" after a valid access.
16. Door Closed            A door has closed after a previous "door left open" alarm.
17. Anti-Tamper Alarm      The reader cable associated with a door has been severed or disconnected. This alarm requires editor acknowledgement, and is printed as an exception.
18. Alarm Cleared         A previous door alarm has been accepted by the system and its cause removed.
19. Override Alarm         The override input on this door controller has activated. This may require editor acknowledgement and is printed as an exception.
20. Override Alarm Reset    The override on this door controller has reset. This is printed as an exception.

## Transaction Types (cont'd.)

21. Manual Lock	A door has been locked manually.
22. Manual Unlock	A door has been unlocked manually.
23. Automatic Lock	A door has been locked automatically by its assigned Time Profile activating.
24. Automatic Unlock	A door has been unlocked automatically by its assigned Time Profile activating.
25. Editor Off	An editor completed editing on the system.
26. Editor On	The editing system was entered by an editor.
27. Alarm Activated	The alarm zone specified has been activated. This event may require editor acknowledgement and is printed as an exception.
28. Sensor Reset	An alarm input has reset following a reported alarm.
29. Automatic Isolate	An alarm input has been automatically disabled by its assigned Time Profile activating.
30. Automatic Engage	An alarm input has been automatically enabled by its assigned Time Profile activating.
31. Local Alarm Accept	A previous alarm (locally accepted) has been accepted at the K2000-AM and passed on to the K6000-AM.
32. No Access: Visit Time	A visitor has attempted to access a door outside the assigned Time Period. This event is printed as an exception.
33. No Access: Unknown ID	A key not present in the system's database has been used. This is printed as an exception.
34. Manual Isolate	Confirmation that an alarm input has been manually disabled.
35. Manual Engage	Confirmation that an alarm input has been manually engaged.
36. Alarm Acknowledged	Confirmation that an operator has acknowledged an alarm. This is printed as an exception.
37. Override Alarm Accepted	Override acknowledged at the PC.
38. RTE Button Held	An RTE button has either gotten stuck, or has been held down too long.
39. Repeated Key Use	User denied access because key was held in front of reader too long.
40. Pin Reader Duress	
41. Duress Acknowledged	
42. Local Duress Accepted	

## Transaction Types (cont'd.)

### EVENT TYPES 43 THROUGH 44 ARE NOT USED

- |                        |  |
|------------------------|--|
| 45. No Exit: Passback  | The key used was presented without having registered as entering or exiting first.                               |
| 46. Exit Out of Hours  | The key was used to exit through an EXIT door after the user's Time Profile (for their Access Code) had expired. |
| 47. Editor Off (Panel) | An editor accessed the K2000-AM editing system.  |
| 48. Editor On (Panel)  | An editor completed editing at the K2000-AM.   |

## Installation

Before installing your K6000-AM, verify that you have the following items:

- 1 K6000-AM software diskette (1 - 3.5" or 2 - 5.25" diskettes).
- 1 reader unit (and cables).
- 1 interface unit (and cables and connectors).
- 1 plug-in line driver module for the K2000-AM Controller.
- K6000-AM User's Guide.

Do **not** begin to install your K6000-AM unless you have all these items. A separate D1625 transformer (16.5 VAC, 25 VA) is also required.

## Layout

Figure 1 shows an expanded K2000-AM system, using the K6000-AM and the maximum number of door controllers attached to the K2000-AM via the 6-wire bus (6WB). For clarity, readers are not shown. The maximum cable distance on the 6WB should not exceed 3,000 ft.

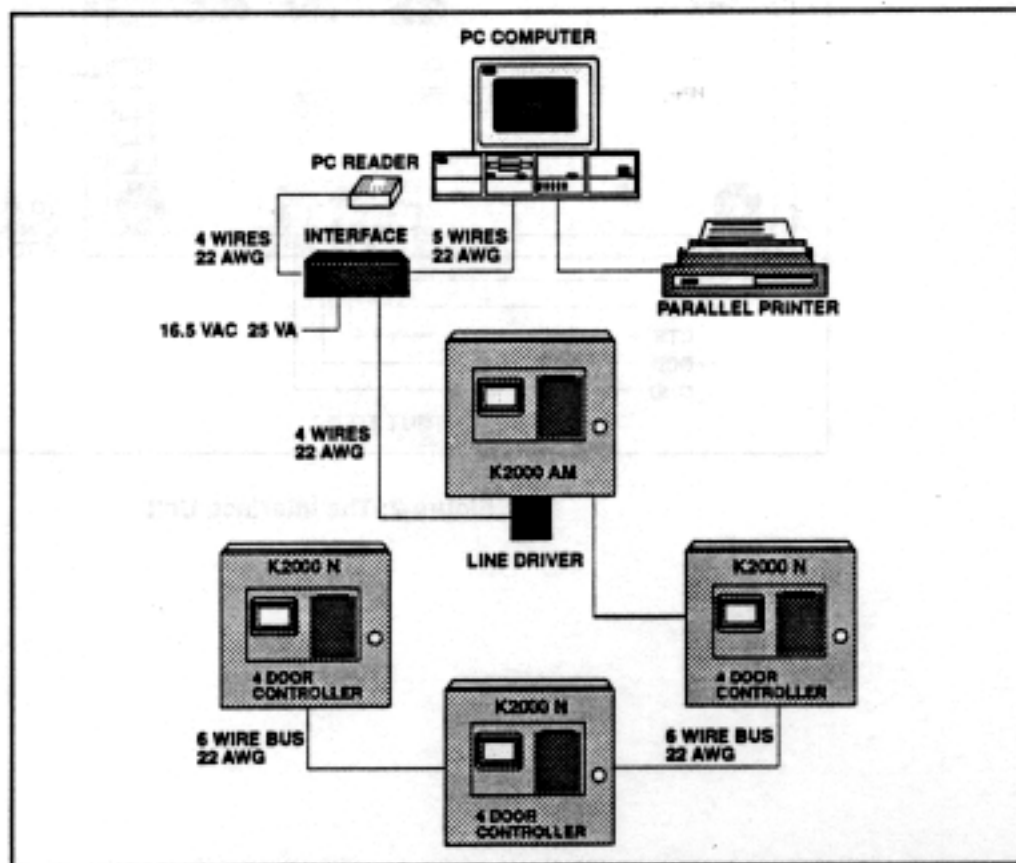

Figure 1: Typical K6000-AM Layout

As the K6000-AM expansion requires the use of the printer port on the K2000-AM, for its communications, the printer facility is transferred to the PARALLEL port on the computer. This port uses the standard parallel printer connections/cable. (See your computer manual for further information on the parallel printer port.)

## The Interface Unit

Figure 2 shows the interface unit, which is supplied as part of the K6000-AM. The interface is the central connection point for the computer, the PC reader, and the K2000-AM Controller. It requires a 16.5 VAC, 25 VA transformer (D1625).

For safety reasons, the K6000-AM interface unit should be installed in the same room as the D1625 transformer.

Wiring connections are clearly shown and should be studied in relation to the layout in Figures 1 and 3.

**Note:** Remove four (4) bottom screws to open unit.

There are no adjustments to be carried out within the interface unit, so once the cables are attached the cover can be secured and the unit placed out of sight.

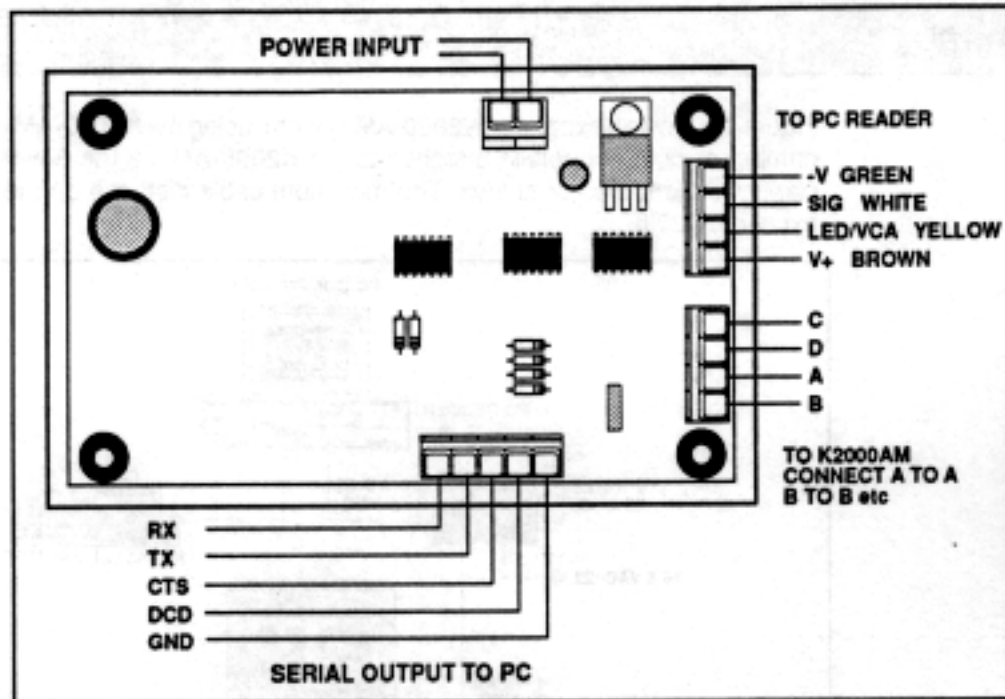

Figure 2: The Interface Unit



## The Line Driver Module

The line driver module supplied with the K6000-AM is a small, encapsulated device that plugs into the serial port on the K2000-AM Controller. It is powered from the serial port. The four connections on the module should be taken to the interface unit at the PC end of the system.

**Note:** The line driver must be used at all times, even if the cable distance is just a few feet.

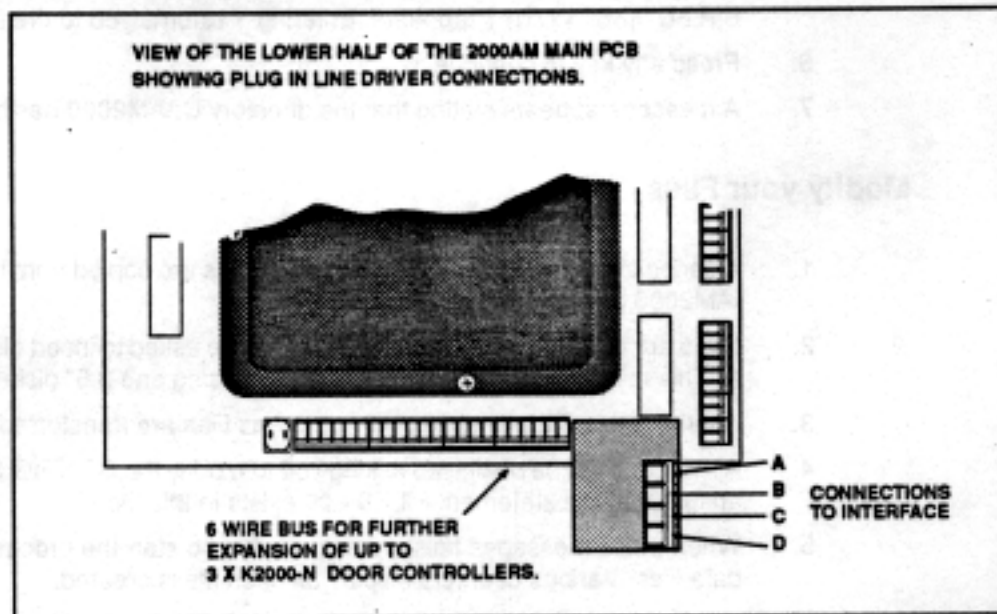

Figure 3: Line Driver Connections

## Software Installation

Software for the K6000-AM comes on either two 5.25" diskettes or one 3.5" diskette. Choose the appropriate size disks for your PC. Before installation, make sure you have at least 10 MBs of space on your hard disk. Ensure that your CONFIG.SYS file is set for at least files=20, buffers=40.

The installation process automatically creates a directory called \AM2000 on drive C: of the hard disk. A number of files are copied from the diskette(s) into this directory.

Statements can be added to the AUTOEXEC.BAT file so that the system starts automatically when the PC is switched on or reset.

To install the software follow the steps below:

1. Start the PC and make sure the DOS C: prompt is at the left of the screen.
2. Place the first (or only) diskette into the diskette drive. If you have both types of diskette drive, use the one that the system understands as drive A:.
3. Type A:INSTALL
4. Press RETURN
5. You will see a message describing the installation process. (To stop the procedure at any stage, hold the CTRL key down and press C. The message "Terminate batch job (Y/N)?" appears. Entering Y returns you to the DOS C prompt.)
6. Press any key to continue.
7. A message appears stating that the directory C:\AM2000 has been created.

### Modify your Files

1. A series of messages will be displayed as files are copied from the diskette to the \AM2000 directory of the hard disk.
2. If you are using two 5.25" diskettes, you will be asked to insert diskette 2 into drive A: This message will not appear if you are using one 3.5" diskette.
3. Another series of messages will appear as files are transferred.
4. A message will be displayed asking you to modify the CONFIG.SYS file. This is to ensure that the statement FILES= 20 exists in this file.
5. When these messages finish, press any key to start the process of creating the data files. Various counters display as each file is created.

### Assign the Master Key

1. When prompted, present the master key to the PC reader, and enter your password. If no password is required, just press ENTER after you have presented the master key. (Any key can be designated for use as a master key.)
2. The Configuration Utility menu appears.
3. Assign the current printer type. Press ESC to return to the DOS C:\prompt.

### Start the K6000-AM

1. To start the K6000-AM, enter K6000AM at the C:\ prompt, then press ENTER.

## Check your System

Before entering any more data, make sure the K6000-AM and the K2000-AM are communicating. If they are, the message **K2000-AM ON-LINE** appears at the top left of the Transaction Monitoring display, with the address number flashing on the 16-character display. If the K6000-AM and the K2000-AM are communicating, proceed to step 1. If they are not, perform the following:

- Make sure the power is connected and switched on at the K6000-AM interface module.
  - Still using the INST command, check that the SYSTEM TYPE is correct. It should read 1.
  - Check that the PC reader is installed correctly. If it is, the LED should change color on presentation of a key.
1. If you have K2000-Ns connected to a K2000-AM, enter their addresses. Each controller should now have its number flashing on the 16 character display if communication is okay.

## Initial Installations

2. If this *is* an initial installation, return to the Installation Configuration menu and initialize all door controllers including the K2000-AM before starting to enter data.

## Subsequent Installations

2. If this is *not* an initial installation (and there is valid data in the K2000-AM), upload the information from the K2000-AM into the K6000-AM using the following procedure:
  - a. Initiate the UL (upload) command from the K2000-AM by pressing the **RESET** button twice.
  - b. Enter the K2000-AM editor using the master password (see the *K2000-AM User Manual*).
  - c. At the CMD prompt, enter UL and press the **ENT** key.

The amount of time the upload takes depends on the amount of data to be transferred. It could take 20 minutes. Once the upload has finished, verify that the data has been transferred to the computer. The data in the K6000-AM should match the data that had been entered in the K2000-AM and the connected K2000-Ns.

## After Checking System

3. Synchronize the system checks.
4. Data can only be entered via the computer now. The K2000-AM front panel will not operate when the SYSTEM TYPE is 1 and the K2000-AM is connected to the K6000-AM.

## Check Your System

Before allowing any more data, there are the K2000-AM and a K2000-AM are...  
...the K2000-AM...  
...the K2000-AM...  
...the K2000-AM...

Make sure the power is connected to the K2000-AM and the...  
...the K2000-AM...

Get into the first console of the K2000-AM...  
...the K2000-AM...

Check that the I/O board is installed correctly...  
...the K2000-AM...

...the K2000-AM...  
...the K2000-AM...  
...the K2000-AM...

## Initial Installation

...the K2000-AM...  
...the K2000-AM...  
...the K2000-AM...

## Subsequent Installation

...the K2000-AM...  
...the K2000-AM...  
...the K2000-AM...

...the K2000-AM...  
...the K2000-AM...  
...the K2000-AM...

...the K2000-AM...  
...the K2000-AM...  
...the K2000-AM...

...the K2000-AM...  
...the K2000-AM...  
...the K2000-AM...

...the K2000-AM...  
...the K2000-AM...  
...the K2000-AM...

...the K2000-AM...  
...the K2000-AM...  
...the K2000-AM...



# Radionics™

T H E Q U A L I T Y L E A D E R

Radionics, Inc., 1800 Abbott Street  
Salinas, CA, 93901, U.S.A.  
Technical Support: (800) 538-5807

™ The Radionics logo is a registered trademark of Radionics, Inc., Salinas, CA, U.S.A.  
© 1993 Radionics, Inc., Salinas, CA, U.S.A. All rights reserved.